

**LT3600**

**User's Manual**



**LT3600  
USER'S  
MANUAL**

**LT3600 Laptop  
Computer**

**User's Manual**

December 1989

Printed in Taiwan

## Notice

The Chicony Electronics Company reserves the right to revise this publication and to make changes from time to time in the contents hereof without obligation to notify any person of such revision or changes.

## Warranty Provisions

The Chicony Electronics Company warrants this personal computer to be in good working order for a period of one year from the date of shipment as a new product. Should this product fails within the one year warranty period, Chicony Electronics Company will with its option, repair or replace this product at no cost except as set forth in the warranty. Repair parts and replacement products will be furnished on an exchange basis and will be either reconditioned or new. All replaced parts and products become the property of Chicony Electronics Company. No warranty is expressed or implied for products damaged by accident, abuse, misuse, natural or personal disaster, or unauthorized modification. No warranties apply after the one year warranty period.

Warranty service described herein can be obtained by delivering this product during the one year warranty period to any authorized distributor or factory in Taiwan. Product should be accompanied by proof of purchase date. The owner agrees to insure and accept all liability loss or damage to this product, to pay in advance all shipping charges, and to use shipping container equivalent to the original packaging.

Chicony Electronics Company is not liable to any purchaser for damage, lost revenue, lost wages, lost savings, or any other incidental or consequential damages arising from the purchase, use or inability to use this product.

(c) Chicony Electronics Company  
Intel is a registered trademark of Intel Corporation.  
IBM PC/XT/AT are registered trademarks of IBM Corporation.  
MS-DOS are registered trademarks of Microsoft Corporation.  
Other brand and product names are trademarks and/or registered trademarks of their respective companies.



## IMPORTANT SAFETY INSTRUCTIONS

1. Read these instructions. Save these instructions for later use.
2. Follow all warnings and instructions marked on the product.
3. Unplug this product from the wall outlet before cleaning. Do not use liquid cleaners or aerosol cleaners. Use a damp cloth for cleaning.
4. Do not use this product near water.
5. Do not place this product on an unstable cart, stand, or table. The product may fall, causing serious damage to the product.
6. Slots and openings in the cabinet and the back or bottom are provided for ventilation; to ensure reliable operation of the product and to protect it from overheating, these openings must not be blocked or covered. The openings should never be blocked by placing the product on a bed, sofa, rug, or other similar surface. This product should never be placed near or over a radiator or heat register, or in a built-in installation unless proper ventilation is provided.
7. This product should be operated from the type of power indicated on the marking label. If you are not sure of the type of power available, consult your dealer or local power company.
8. This product is equipped with a 3-wire grounding type plug, a plug having a third (grounding) pin. This plug will only fit into a grounding-type power outlet. This is a safety feature. If you are unable to insert the plug into the outlet, contact your electrician to replace your obsolete outlet. Do not defeat the purpose of the grounding-type plug.
9. Do not allow anything to rest on the power cord. Do not locate this product where persons will walk on the cord.

10. If an extension cord is used with this product, make sure that the total of the ampere ratings on the products plugged into the extension cord does not exceed the extension cord ampere rating. Also, make sure that the total of all products plugged into the wall outlet does not exceed 15 amperes.
11. Never push objects of any kind into this product through cabinet slots as they may touch dangerous voltage points or short out parts that could result in a risk of fire or electric shock. Never spill liquid of any kind on the product.
12. Do not attempt to service this product yourself, as opening or removing covers may expose you to dangerous voltage points or other risks. Refer all servicing to service personnel.
13. Unplug this product from the wall outlet and refer servicing to qualified service personnel under the following conditions:
  - a. When the power cord or plug is damaged or frayed.
  - b. If liquid has been spilled into the product.
  - c. If the product has been exposed to rain or water.
  - d. If the product does not operate normally when the operating instructions are followed. Adjust only those controls that are covered by the operating instructions since improper adjustment of other controls may result in damage and will often require extensive work by a qualified technician to restore the product to normal operation.
  - e. If the product has been dropped or the cabinet has been damaged.
  - f. If the product exhibits a distinct change in performance, indicating a need for service.
14. Replace battery with the same type as the product's battery we recommend. Use of another battery may present a risk of fire or explosion. Refer battery replacement to a qualified serviceman.

15. **Warning:** Battery may explode if mistreated. Do not recharge, disassemble or dispose of in fire. Keep away from children and dispose of used battery promptly.
16. Use only the proper type of power supply cord set (provided in your keyboard/manual accessories box) for this unit. It should be a detachable type: UL listed/CSA certified, type SVT/SJT, rated 6A 125V minimum, VDE approved or its equivalent. Maximum length is 15 feet (4.6 meters).
17. There are two things to remember in using the "EAGLE" utility:
  - a. Do NOT use the "PANEL/CRT" switch when changing screen from PANEL to CRT. "CRT.COM" or "LCD.COM" must be used because the LCD PANEL may be damaged.
  - b. The version of "EAGLE" utility does not support Video extension mode.
18. Charge the battery at least 4 hours. This will assure you of the 5-minute time limit to save your data. Otherwise, the battery will not be able to save your data due to low power. Therefore, follow the minimum charging time in order to save your data to the hard disk before the system shuts down.



# Table of Contents

## 1 Getting Started

Taking a First Look.....	1-1
The Screen .....	1-3
Selecting an Operating Environment .....	1-4
Power Source.....	1-4
Display Power Saver Feature.....	1-4
Applying Power .....	1-6
The Battery .....	1-7

## 2 System Description

Standard Components.....	2-1
System Unit Controls and Indicators.....	2-2
The Keyboard .....	2-7
Alphanumeric Key Group.....	2-8
External Numeric Keypad .....	2-10
Edit Keypad .....	2-11
Cursor Keys.....	2-11
Function Key.....	2-11
Flexible Disks and Drives .....	2-12
Inserting/Removing Flexible Disks.....	2-12
Write-Protecting Flexible Disks.....	2-12
Do's and Dont's.....	2-13
Fixed-Disk Drives.....	2-13

80286 Microprocessor .....	2-15
Numeric Coprocessor.....	2-15
RAM .....	2-15
Memory Expansion Module Sockets.....	2-18
ROM .....	2-18
Optional Components.....	2-19

### **3 Installing Your System**

Before You Begin .....	3-1
Components Checklist.....	3-2
Installing Optional Components.....	3-3
Installing Onboard Memory Expansion Module .....	3-4
Installing Memory Modules.....	3-5
Installing Numeric Coprocessor.....	3-9
Installing Expansion Boards .....	3-11
Installing 5.25-inch Flexible-Disk Drive.....	3-14
Setting the CPU Speed .....	3-17
Using Fn key.....	3-17
Using Soft Switches .....	3-21
Connecting Input/Output (I/O) Devices.....	3-24
Connecting an External Monitor.....	3-24
Connecting a Printer .....	3-24
Connecting a Keyboard .....	3-25
Connecting a Modem.....	3-25
Connecting a Mouse.....	3-26
Connecting the System to a Power Outlet.....	3-26

Starting Up the System.....	3-26
Power-On Self Test (POST).....	3-27
Help Functions.....	3-28

#### **4 Running the Setup Program**

When does the System Prompts You to Run Setup?.....	4-1
Running the Setup Program.....	4-3
Extended Setup.....	4-15
Easy NEAT Chipset Register Setup.....	4-19
Memory Configurations.....	4-19
Clock Settings.....	4-20
Processor Clock.....	4-20
Bus clock.....	4-20
Direct Memory Access Clock.....	4-21
Shadow RAM and Memory Interleave.....	4-21
Advanced NEAT Chipset Register Setup.....	4-22
Setting 82C206 -- Clock and Wait States Control....	4-22
Setting XIOR/XIOW Wait State.....	4-22
Setting 16 -- Bit DMA Wait State.....	4-22
Setting 8 -- Bit DMA Wait State.....	4-23
Setting the EMS bit.....	4-23
Setting the DMA clock.....	4-23
Setting the Version Register -- RB0 (64h index) 82C212 4-24	
Setting the ROM Configuration Register -- RB1 (65h index).....	4-24

Setting the Memory Enable-1 Register -- RB2 (66h index).....	4-25
Setting the Memory Enable-2 Register -- RB3 (67h index).....	4-26
Setting the Memory Enable-3 Register -- RB4 (68h index).....	4-27
Setting the Memory Enable-4 Register -- RB5 (69h index).....	4-28
Setting the Bank 0/1 Enable Register -- RB6 (6Ah index).....	4-29
Setting the DRAM Configuration Register -- RB7 (6Bh index).....	4-29
Setting the Enable Register -- RB8 (6Ch index).....	4-32
Setting the Base Address Register -- RB9 (6CD index)4-33	
Setting the EMS Address Extension Register -- RB10 (6Eh index).....	4-34
Setting the Miscellaneous Register -- RB12 (6Fh index)4-36	
Setting Memory Type and Size.....	4-43
Setting Zero Wait States .....	4-44

## 5 Operating Your System

System Software Utilities .....	5-1
NEATEMM Utility .....	5-3
Running the Utility .....	5-10

## 6 Problem Solving

Identifying and Solving System Problems .....	6-2
Problems at Initial System Startup .....	6-2
Problems With a Fixed Disk Drive .....	6-5
Problems With a Diskette Drive .....	6-6
Problems When Running a New Application Program. 6-8	
Problems After the System and Software are Running Correctly .....	6-9
Problems With Peripheral Devices and Other Optional Components .....	6-9
Power-On Self-Test Error Codes .....	6-11
Troubleshooting .....	6-14
Does your system boot and displays the boot message? .....	6-14
Does the display shows a Memory Size Mismatch?. 6-15	
Is there a fixed-disk drive failure? .....	6-15
Is there a flexible-disk drive failure? .....	6-16
Is there a keyboard failure? .....	6-16
Are there any error beeps .....	6-17
Do you have COM1, COM2, or Printer port failure? . 6-17	
Other Troubleshooting Tips .....	6-18



Using a LED connected to port 80h.....	6-18
List of Check Points.....	6-19
Error Messages.....	6-23
Errors Reported by the System.....	6-25
Fatal Errors.....	6-25

## **7 Caring for the System**

Maintenance.....	7-1
Moving the System.....	7-2
Packing the System.....	7-4

## **A p p e n d i c e s**

<b>Appendix A</b>	<b>System Specifications</b>
<b>Appendix B</b>	<b>I/O Ports Connectors</b>
<b>Appendix C</b>	<b>Programming LVGAKEYB.COM Functions</b>
<b>Appendix D</b>	<b>ASCII Character Codes</b>
<b>Glossary</b>	
<b>Index</b>	

## Scope

This manual is an installation and operation guide to your laptop. It consists of just seven chapters, arranged according to subject and intended audience, plus additional reference material located in the appendices.

The manual covers the following topics:

- Learning about system features (drives, connectors, lights, switches)
- Assembling and operating the system
- Dealing with operating problems and error messages
- Loading configuration values
- Controlling operations from the keyboard
- Installing or modifying system hardware

## Audience

The manual is intended for three general types of readers:

- Non-technical buyers and operators running application software in a business or personal-use environment.
- Business and technical purchasers who want to develop software and hardware packages to customize the system for a specific environment.
- Readers with some technical background, such as designers, programmers and technicians, who intend to modify the system hardware and configure the system.

**Chapter 1**  
**GETTING**  
**STARTED**





# Getting Started

This chapter presents a quick path for installation of the system.

## Taking a First Look

The LT3600 laptop is a portable personal computer (PC) that includes a 3.5-inch flexible diskette drive, a liquid crystal display (LCD), 40-MB embedded fixed-disk drive and a controller, an embedded computer-like keyboard (82-key), a nickel-cadmium (NiCad) rechargeable battery, status indicating light-emitting diodes (LEDs) and an ac-dc adapter.



The motherboard is an 80286-based system with a built-in VGA chip to support high resolution display. The system is an AT-compatible PC running at speed of 20 MHz. It contains 1 MB of onboard RAM, expandable to 5 MB using a proprietary memory expansion board.

The 11-inch VGA backlit LCD screen offers excellent clarity, displaying 25 lines by 80 characters of eminently readable text as well as VGA graphics. The hinged screen covers the keyboard and opens to an angle of about 135 degrees. The VGA backlit LCD display supports high-resolution VGA text and graphics (640 x 480).

The rear panel has connectors for serial and parallel devices, 5.25-inch flexible disk drive, external monitor, printer, and external keyboard/keypad.

You can attach optional peripherals on both sides, such as an external keypad and 101-/102-key keyboard, modem, proprietary memory expansion board. The base has a space for adding a numeric coprocessor.

Weighing less than 19.8 lbs equipped with a 40-MB fixed disk, the LT3600 incorporates the capabilities of a powerful desktop computer into a small, lightweight, AC and/or battery-powered system.

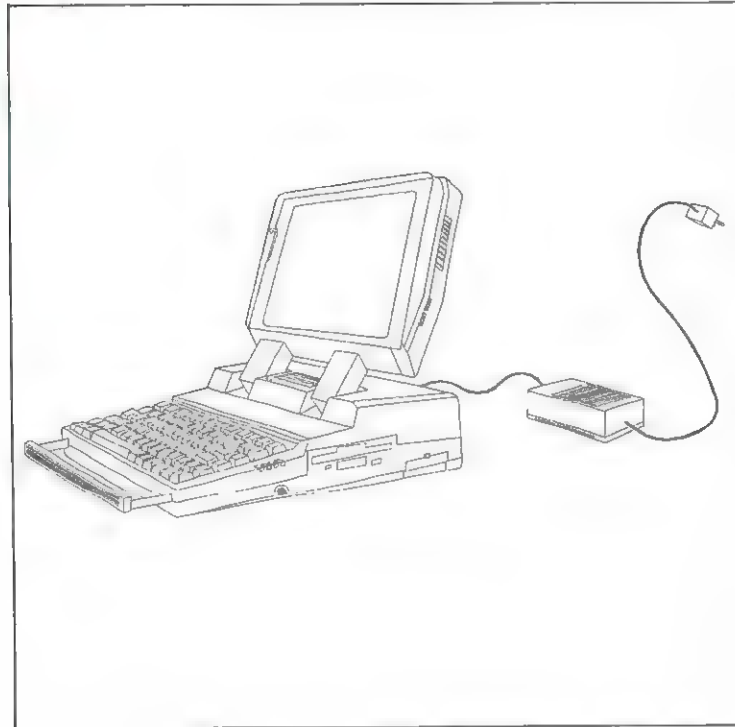

Figure 1-1. The LT3600 Laptop

## The Screen

The LT3600 portable laptop has a 25-line, 80-characters-per-line, backlit LCD screen. You can tilt the display screen to an angle you prefer. You can also adjust display contrast for optimum legibility. The display folds down to form a cover over the keyboard when the laptop is not in use.

Open the display as follows:

1. Push the latches located on both sides of the laptop case.
2. Tilt the display to the desired angle you prefer.
3. To close the display, gently push down on the display case until the latch locks.

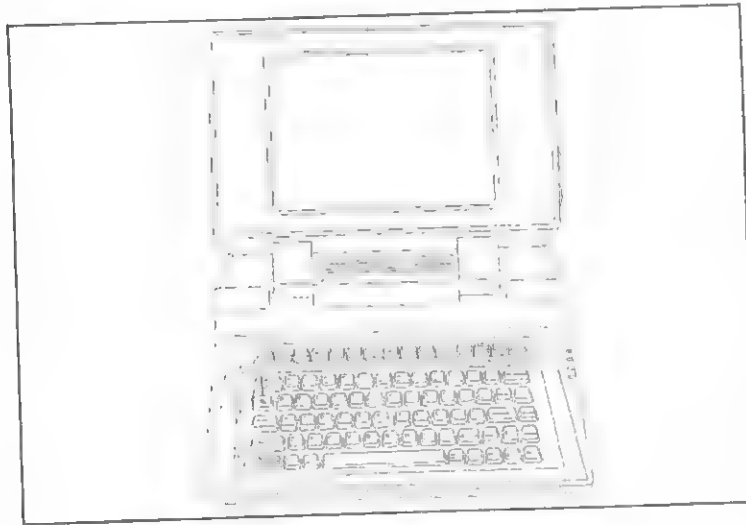

Figure 1-2. Lifting the Screen Cover

## Selecting an Operating Environment

You can operate your LT3600 laptop in your office, your home - even in your vehicle or outdoors if your LT3600 has the NiCad battery pack. When using your laptop:

- You can operate your LT3600 in almost any environment where the temperature and humidity are comfortable enough for you to work.
- Place the laptop within cable length of your external modem, printer, or other local device, when using the standard serial or parallel interface connector.

## Power Source

Your laptop comes with a detachable power cord designed to plug into a 110/220-V<sub>ac</sub>, 60-Hz, power outlet.

A rechargeable battery pack is available as an alternate power source or as backup power. The battery pack automatically recharges any time the LT3600 is plugged into an ac power source, whether the LT3600 is on or off.

## Display Power Saver Feature

You can set the display power saver feature at some preset period of inactivity by using the Setup program. The screen blanks after a selected period of inactivity. Chapter 4 explains the Setup program.

## Fixed Disk Power Saver Feature

You can set the fixed disk power saver feature at some preset period of inactivity by using the Setup program. The fixed disk turns off after a selected period of inactivity. Chapter 4 explains the Setup program.

The LT3600 was designed with special features to minimize system power consumption. These are LCD SLEEPING MODE and HDD SLEEPING MODE. The function of a sleeping mode is to turn off the power of both LCD and HDD while the keyboard is inactive. The time of inactivity can be set through the CMOS SETUP program. The range is from 0 to 7 minutes. When the time you set for LCD and HDD expires, it automatically turns off their respective power. Just press any key to turn the power on again. In case a conflict occurs with the software and you can't turn the "LCD backlight" ON, set the timer of the LCD to zero. This means that sleeping mode is off.



## Applying Power

Connect the power cord to your LT3600 as follows:

1. Press the power switch located on the right side of the laptop to Off position.

**Note:**

Ensure that the AC input voltage specified on the power cord matches the voltage available at your wall outlet. Serious damage to the LT3600 can result from incorrect input voltage.

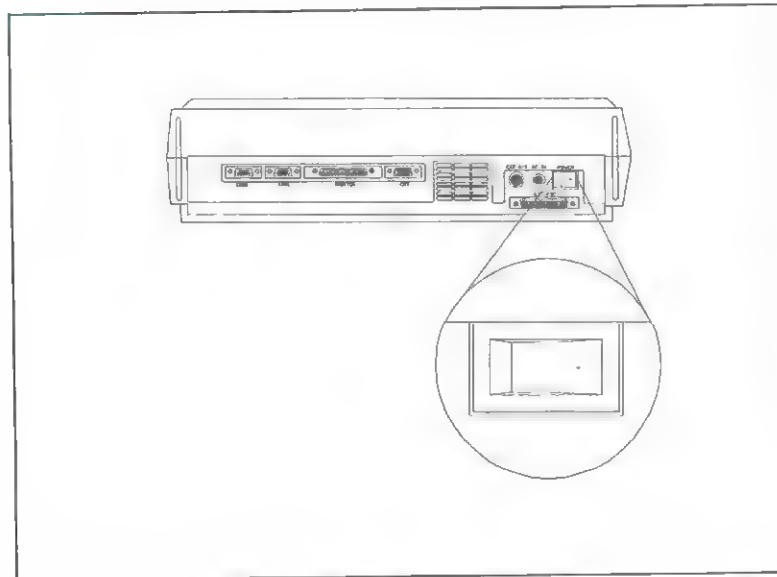

**Figure 1-3. Turning On the Laptop**

2. Plug the small power cord connector into the power socket on the rear side of the LT3600.
3. To turn on your LT3600, press the power switch to On (●) position. The laptop performs a power-on self-test (POST). Chapter 4 shows all the possible screen message during the POST and Setup. Refer to Chapter 6 on error messages and problem solving guide.

**Note:** If the screen is blank and the Power LED is ON, slide the contrast control to MAX (maximum) until an image appears, then adjust the brightness and display angle for clarity.



## The Battery

The system unit has one set of NiCad battery cascaded with 1.2 V \* 10 4400 mAh of power. When the battery is low, an alarm will sound indicating a low power in the battery. You must save your data as soon as you hear the warning sound for a low battery.

## Thermal Protection

The battery is protected with two thermal switches. The charging path is cut when the body temperature of the battery rises to 45 degrees while the discharging path is cut when the body temperature of the battery rises to 70 degrees.



## Charging Time

You can charge the battery with the ac adaptor when the battery power is low. To keep the capacity of the battery to 70%, you need about four hours of charging time. For 90% battery capacity, the charging time is about eight hours or more.



## Discharging Time

You can operate the system for about two hours continuously when the battery capacity is about 90% or more. The operating time is longer when the LCD screen's brightness is kept low and the system performs power save.

## Battery Life

Fully charging the battery and then discharging or depleting the battery is called one full cycle of battery life. The system has about 500 charge/discharge cycles.

## Battery LOW Warning and Operating Time

Low battery power is indicated by a repeating sequence of 2 beeps. The "battery low" LED will also light up. The user can press any key to stop this sound and continue operating the system. The user, however, should save any important data as soon as possible because the system would shut down in approximately 5 minutes.

The battery LOW operating time depends on the duration the battery has been charged. It is recommended for the user to charge the battery for more than 4 hours in order to assure him of the 5-minute time limit before the system shuts down. The time limit starts right after the first beep is heard.

The user should also be careful in writing data to the hard disk after the 5-minute period. The system can shut down anytime and this might result in losing some data in the hard disk.



Notes:



Chapter 2  
**SYSTEM**  
**DESCRIPTION**



## System Description

This chapter presents an overview of the system and its major components. The features and capabilities of the system are introduced. Both the standard system configuration and expansion capabilities are described.

### Standard Components

The standard configuration of the system board includes the following:

- 20-MHz/10-MHz 80C286-16 microprocessor and support circuitry
- Socket for Intel 80287-6/12 numeric coprocessor
- Erasable Programmable Read-only memory (EPROM), with American Megatrends Incorporated (AMI) ROM BIOS
- Onboard 1 MB Dynamic Random Access Memory (DRAM)
- Four memory expansion module sockets
- One 16-bit expansion slot for half-sized PC XT/AT board
- One configurable IBM-AT compatible parallel printer port
- Two configurable IBM-AT compatible RS-232C serial communication ports
- Powerful PC-AT chip set from Chips and Technologies

## System Unit Controls and Indicators

The features of the system unit front, rear, and right panel are shown in Figures 2-1 to 2-3.

The front panel of the system unit (see Figure 2-1) consists of the following:

1. **PWR - Power Indicator.** This indicator is lit when the system power is on.
2. **TUR - Turbo Speed Indicator.** This indicator is lit when the system runs at 20 MHz (default speed).
3. **HDD drive in-use light.** This indicator lights when the fixed-disk drive is accessed.
4. **FDD drive in-use light.** This indicator lights when the flexible-disk drive is accessed.
5. **Brightness Control.** This control is used to adjust the brightness of the screen.
6. **Contrast Control.** This control is used to change the contrast of the screen.
7. **DC IN - DC Input Indicator.** This indicator lights with a red color when external DC power is used.
8. **BAT LOW- Battery Low Indicator.** This indicator lights when battery power is low, giving a warning to save the current data to prevent loss of data.

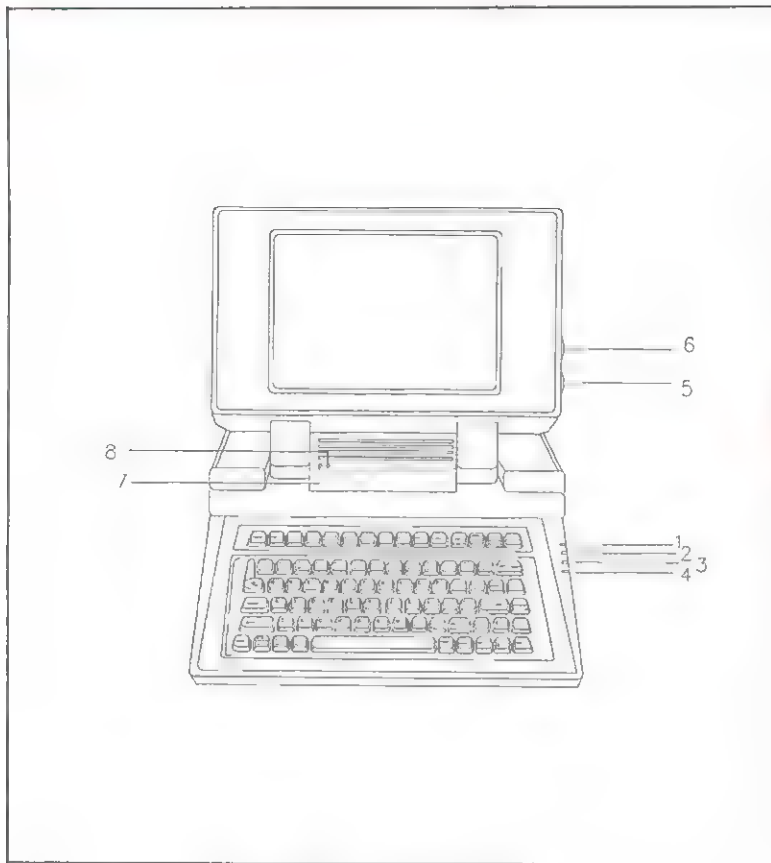
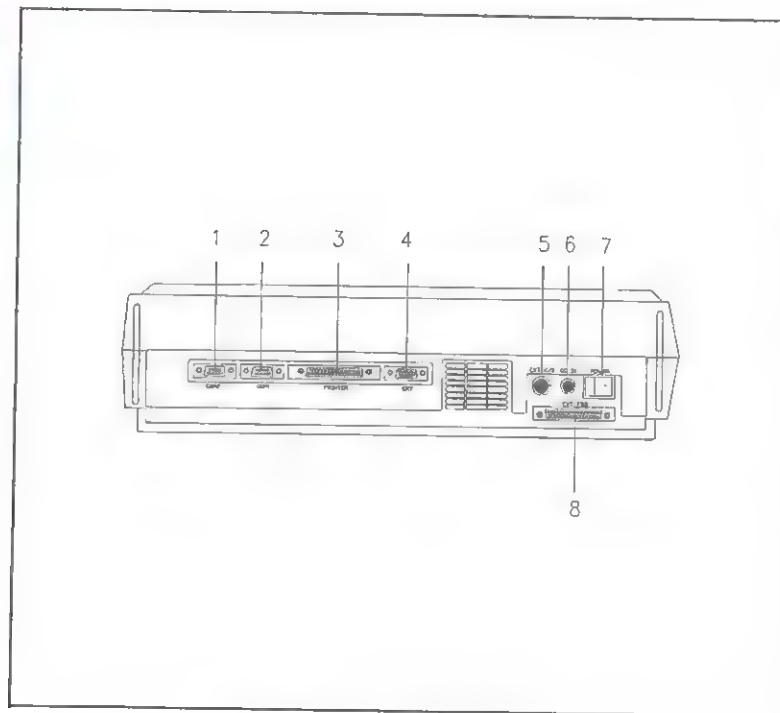

Figure 2-1. Front Panel

The rear panel of the system unit with the covering plate (see Figure 2-2) consists of the following:

1. **COM2 - Serial Port Connector.** Any serial device such as mouse and modem cable connector are attached here.
2. **COM1 - Serial Port Connector .** Any serial device such as mouse and modem cable connector are attached here.
3. **Parallel Printer Port.** Any parallel printer device can be connected by inserting the connecting cable here.



**Figure 2-2. Rear Panel**

4. **CRT - External Monitor Port.** The external monitor connecting cable is inserted here.
5. **Ext K/B - External Keyboard Connector.** You can connect an external 101-/102-key keyboard in this port.
6. **DC IN Power Socket.** This is where the system ac adapter or external dc power cable is inserted.
7. **System Power Switch.** The system unit power switch, on the left side of the system unit, is pushed up or down to put the system to on or off.
8. **Ext FDD - External 5.25-inch Flexible Disk Drive (FDD) Port Connector.** This is where the flexible-disk drive cable connector is inserted.



The right panel of the system unit (see Figure 2-3) consists of the following:

1. **Front Panel Indicators.** Contains all the front panel LED lights.
2. **3.5-inch flexible-disk drive.** The 3.5-inch flexible diskette is inserted here. Pressing the button on its lower right side removes the inserted diskette.
3. **External Expansion Board Slot.** You can insert an internal modem board or LAN board in this 16-bit expansion slot.
4. **NUM PAD - External Keypad Connector.** The coiled numeric keypad connector is inserted here.

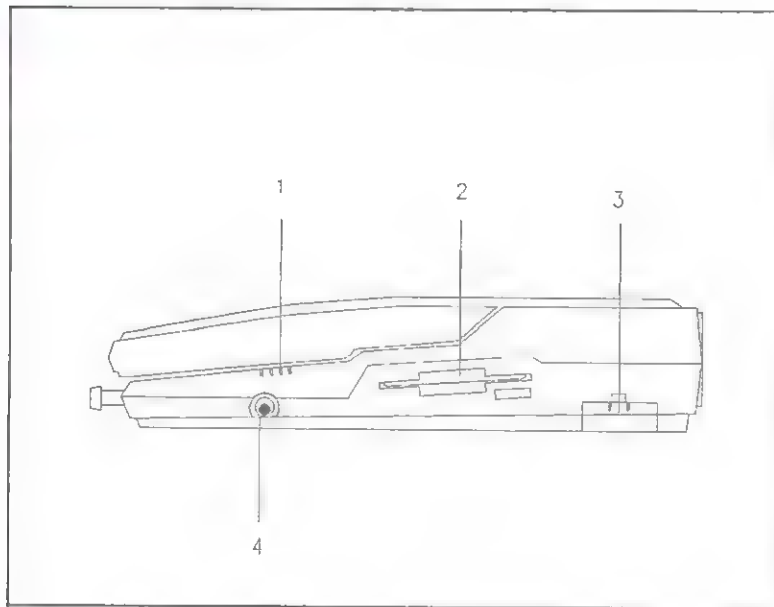

Figure 2-3. Right Panel

## The Keyboard

The 82-key keyboard is compatible with IBM AT 101 keyboard. The three indicator lights (Caps lock, the Num lock, and the Scroll lock) of the keyboard are located on the corresponding keys in the laptop.

The 82-key keyboard has the functions of an IBM AT compatible keyboard. You can attach a 101-/102-key keyboard to the system using the keyboard converter cable.

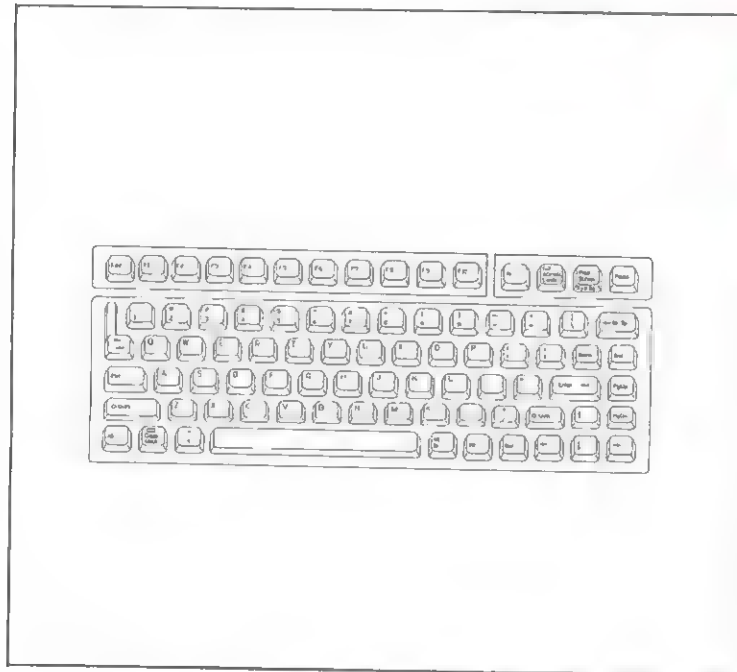

Figure 2-4. The LT3600 Laptop Keyboard

The keyboard is divided into five sections:

- Alphanumeric key group
- Edit keypad
- Cursor control keys
- Functions keys
- External numeric keypad

### Alphanumeric Key Group

The alphanumeric key area is the main part of the keyboard; it is used for entering most of your data.

This section contains the alphanumeric keys which you use in the same way as you use a typewriter. Special characters and punctuation marks are displayed when used with the Shift key and character/punctuation keys. Non-character keys are also included:

Enter

The Enter key is equivalent to the typewriter's Carriage Return. When this key is pressed, the cursor will move to the beginning of the next line.

< --

Backspace. This key moves the cursor one position to the left of its current position. In many software applications, this key also deletes the character from the position the cursor has moved to.

The Tab key shifts the cursor a number of spaces to the right. Pressing the Tab key while holding down the Shift key will move the cursor a number of spaces to the left.

The Shift key switches the keys in the alphanumeric key area and numeric keypad from lowercase to uppercase. Two Shift keys are found on the left and right side of the alphanumeric key area.

#### Caps Lock

This key is used for entering uppercase letters. Upon pressing the Caps lock key, the Caps lock indicator lights. Caps lock does not affect special characters and some punctuation marks. To return to the lower case mode, press the Caps lock again.

#### Ctrl

The Control key is used with other key(s) to perform a certain function or command.

#### Alt

The Alternate has various uses with different software applications.

**Fn**

The Fn key is equivalent to the Ctrl + Alt key combination. It functions as a display selection key when combined with other keys.

### External Numeric Keypad

 On the right part of the keyboard is a 13-pin DIN connector for an external numeric keypad. When the numeric keypad is connected, it serves as the *numeric* key group of the keyboard. The keys have two functions, depending on whether they are in the *numeric* or the *cursor control* mode. The default mode is the numeric control mode. In this mode the Num lock indicator is lit. In the cursor control mode the cursor can be shifted one space to any of the four directions indicated on the keys. To move the cursor more than one space, you have to either press the keys several times or hold the key down a little longer. The latter feature is called *Auto-repeat*.

Use the Num lock key to toggle between the numeric mode and the cursor control mode.

### **Edit Keypad**

Between the numeric keypad and the alphanumeric key group are the six keys that perform software-defined functions related to data editing. The keys are labeled Ins, Del, Home, End, PgUp, and PgDn. Refer to your software or operating system documentation for more information on the use of these keys.

### **Cursor Keys**

The four arrow keys below the Enter key are used to move the cursor on the screen in the direction of the arrow on the key. Use these set of keys when the Num lock indicator is lit and the numeric keypad is in the numeric mode.



### **Function Key Group**

Ten function keys are located at the top of the keyboard. Their functions are determined by the software or operating system you are using. Refer to the documentation of the operating system or software for an explanation of their functions.

## Flexible Disks and Drives

### Inserting/Removing Flexible Disks

1. Handle a flexible disk by its edges.
2. With the label side up, insert the diskette gently into the drive until the diskette is properly seated.
3. For 5.25-inch disk drives, turn the drive latch clockwise to close the drive door. For 3.5-inch disk drives, press the drive button to close the drive door.
4. To remove a diskette from a drive, turn the latch counterclockwise (for 5.25-inch drive) or press the drive button (for 3.5-inch drive).

### Write-Protecting Flexible Disks

To prevent data on a diskette from being erased, place a write-protect tab over the write-protect notch. You cannot write data to a write-protected diskette. When you have to write data onto a diskette, remove the write-protect tab.

## Do's and Dont's

- Always make backup copies of software diskettes.
- Each time you finish creating or modifying an important file, back it up on a diskette.
- When a diskette is removed from a diskette drive, return it immediately to its envelope.
- Only use a soft-tip pen to write on a diskette label. Do not use a ball point pen.
- Keep diskettes away from any magnetic fields.
- Store diskettes in a safe place in a 50° to 125°F (10° to 52°C) temperature range.
- Do not remove diskettes from a drive when the diskette in-use light is on.
- Do not touch or scratch the exposed portion of a diskette at the head aperture, or allow dust or moisture to collect on a diskette.
- Do not bend or throw diskettes.

## Fixed-Disk Drives

All fixed disks must be physically formatted, partitioned, and logically formatted before use. The fixed disk that comes with your system from the factory has been physically formatted. See MS-DOS documentation explaining the FDISK utility. The FORMAT command in DOS logically formats the drive.



The following figure (Figure 2-5) shows the system board location of the central processing unit (CPU), read only memory (ROM), random access memory (RAM), numeric coprocessor socket, four memory expansion module sockets, and one expansion slot.

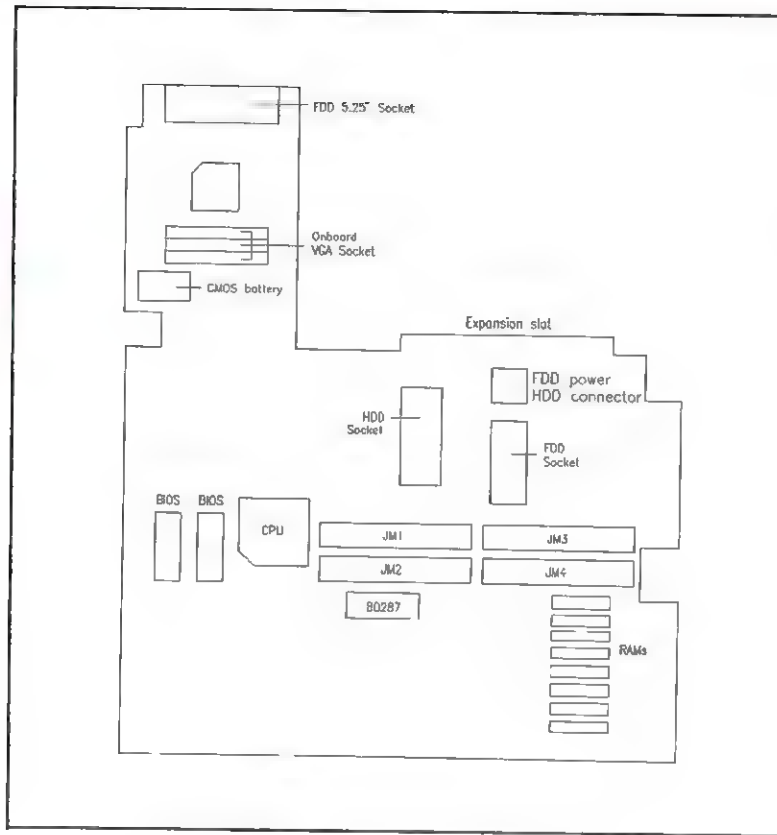

**Figure 2-5. System Board Layout**

### **80C286 Microprocessor**

The 80C286 is a 16-bit, high-performance, state-of-the-art microprocessor that is fully upward compatible with 8088 software. In addition to offering 8088 compatibility, the 80C286 supports memory management and protection, virtual addressing, and multitasking environments. The CPU architecture of 80C286 allows sophisticated memory management and process control functions. With the 24 address lines in the 80C286, it could calculate four to five times faster than an 8086 running at the same clock speed.

### **Numeric Coprocessor**

The system includes a socket for the 80287 numeric coprocessor to the 80C286 processor. The 80287 extends the ability of the personal computer to perform high-speed, high-accuracy floating point computations by extending the register and instruction set available for computation. It supports a number of built-in functions providing arithmetic and transcendental (trigonometric and logarithmic) functions.

### **RAM**

Three basic types of RAM exist in the PC environment: conventional (or base) memory, expanded memory, and extended memory.

*Conventional memory* is located within the address range of 0 and 9FFFFh. This space contains 640 KB of memory. Present versions of DOS cannot address more than 640 KB of conventional memory. XENIX and UNIX do not have this limitation because both of these operating systems execute all instructions in protected mode.

*Expanded memory* adheres to the LIM (Lotus-Intel-Microsoft) specification, which allows DOS applications a window in which to access more than 640 KB of memory.

*Extended memory* is memory whose addresses begin at 100000h. Memory can only be accessed when the processor is in protected mode. Extended memory up to 16 MB (FFFFFFh) is available to the user.

The system board has up to 1 MB of onboard memory. It has no user-configurable memory space between 640 KB and 1024 KB. The table below summarizes the allocation of the first 1024 KB of address space.

**Table 2-1. Memory Address**

<b>Memory Usage Location</b>	<b>Amount</b>	<b>Address</b>
System RAM	640 KB	00000~9FFFF
Video RAM	128 KB	A0000~BFFFF
Video BIOS	32 KB	C0000~C7FFF
Reserved	160 KB	C8000~EFFFF
System BIOS	64 KB	F0000~FFFFF

Some software packages can now specify part of the extended memory as expanded memory. These softwares emulate the LIM specification.

**NOTE:** Many DOS software applications are not designed to utilize expanded or extended memory. No matter how much expanded or extended memory is present, it cannot be used by your application unless this capability has been specifically designed into the application software.

## Memory Expansion Module Sockets

The system board contains four sockets for holding memory expansion module that comprise the onboard system RAM. These modules are small boards with nine DRAM chips. The modules are organized in two configurations: 256 KB x 9 and 1 MB x 9. For 1 M of RAM there should be an equivalent of four 1 MB modules to expand the system to 5 MB of DRAM.

Memory modules are also grouped into three modes of operation: static mode, fast page-mode, and RAS/CAS mode. Static column mode provides the highest system performance, followed by fast paged-mode, and RAS/CAS mode in that order.

The memory modules are pinned-type SIMMs (Single-in line memory modules). All memory modules operate at 100 ns for 1-MB memory modules and 80 ns for 256-KB memory modules. See Chapter 3 for instructions on how to install memory modules.

## ROM

The ROM (Read Only Memory) on the system board contains the system BIOS and the setup program. The ROM occupies the upper 64 KB of address space in the first megabyte. A setup program option (shadowing the system BIOS) allows the system BIOS to be copied into 16-bit RAM for faster access. In addition, a shadow option is provided for video BIOS that may be present on a video adapter board.

The 16-bit RAM copy is set at the same address as the ROMs to give compatibility with programs that use absolute addresses when accessing the system and video BIOS.

With ROM copied into 16-bit RAM, the CPU can access the BIOS at the same speed it accesses other onboard RAM. All accesses to the BIOS are then made to this copy. The system board architecture ensures that the copy in RAM is write-protected so that programs cannot inadvertently overwrite the information.

The BIOS supplied with the system board is compatible with the BIOS in the IBM AT, so long as the programs that access the BIOS use software interrupts and do not assign absolute memory locations. Programs that refer to absolute locations in the IBM AT BIOS may not function correctly when running on the system board.

**NOTE:** Unlike the IBM AT, the system board ROM does not contain code for the BASIC interpreter. Therefore, the IBM BASIC and BASICA interpreters will not run on this system board. Instead, users should acquire Microsoft's GW-BASIC interpreter for use in this system.



In addition to the BIOS, the ROM contains the setup program used to configure the system. Users can access the setup program by a simple keyboard sequence instead of having to insert a diskette and invoke the setup program from DOS.

## Optional Components

A variety of options can be added to the system to expand system capabilities. These options include:

- 5.25-inch diskette drive

- Expansion board
- 80287 Numeric coprocessor
- SIMM (single in-line memory module)

You can increase the speed of your system by adding a Harris 80287 and a SIMM memory module.



**Chapter 3**  
**INSTALLING**  
**YOUR**  
**SYSTEM**



1  
2  
3  
4  
5  
6  
7  
8  
9  
10  
11  
12  
13  
14  
15  
16  
17  
18  
19  
20  
21  
22  
23  
24  
25  
26  
27  
28  
29  
30  
31  
32  
33  
34  
35  
36  
37  
38  
39  
40  
41  
42  
43  
44  
45  
46  
47  
48  
49  
50  
51  
52  
53  
54  
55  
56  
57  
58  
59  
60  
61  
62  
63  
64  
65  
66  
67  
68  
69  
70  
71  
72  
73  
74  
75  
76  
77  
78  
79  
80  
81  
82  
83  
84  
85  
86  
87  
88  
89  
90  
91  
92  
93  
94  
95  
96  
97  
98  
99  
100



## Installing Your System

This chapter describes how to install and set up the system. It includes detailed instructions on installing optional components, setting system board switches, connecting peripherals, starting the system, etc. The novice end-user should read this chapter carefully.

### Before You Begin

Before installing the system, make sure that:

- The system unit power switch is off.
- All power cords and cables are disconnected.

After unpacking all of the components, save all boxes and packing materials for moving or shipping your system.



## Components Checklist

Check to see that in addition to this User's Guide the following items are present and in good condition:

- System module and carrying bag (optional) and system power cord
- Two RS232C serial converter cables
- 5.25-inch flexible-disk drive cord
- 5.25-inch flexible-disk drive chassis
- Numeric keypad and external keyboard converter cable
- System utilities diskette
- External ac adapter

If anything is damaged or missing, contact your service representative.



## Installing Optional Components

When you have to add optional devices to the system, you must prepare the system unit to ensure proper installation of the components and your own safety. These components include:

- Onboard RAM
- Numeric coprocessor
- Expansion boards
- 5.25-inch flexible-disk drive (1.2 MB capacity)



3



## Installing and Removing Onboard Memory Expansion Module

Before you install or remove the onboard RAM:

1. Turn off the system unit power.
2. Remove the seven screws on the base of the system unit, the three screws on the upper portion of the the front side of the system (near the system's handle), and the two screws on both sides of the rear panel. Remove the system unit cover.
3. Remove the four screws on the internal keyboard and then lift the internal keyboard.



**Note:**

Each memory module is a small card containing nine memory chips. The chips can be in a 256K-bit x 1 organization for a total of 256 KB on each module or 1 M-bit x 1 chips for a total of 1 MB on each module. These memory modules are pinned-type RAM module.



## Installing Memory Modules

Install memory modules in banks JM1 and JM3 (see system layout), in that order for the first 2-MB memory expansion module while banks JM2 and JM4 are for the second 2-MB memory. Single in-line memory modules (SIMMs) should be installed in pairs. Note that each bank (JM1 and JM3) has two slots. When installing SIMMs, both slots should be filled. Expand the system memory up to 5 MB by installing SIMMs in banks JM1, JM3, JM2 and JM4. Table 3-1 shows the memory capacity of each bank.

**Table 3-1. Memory Capacity of Each Bank**

<b>Bank Number</b>	<b>Memory Capacity</b>
Bank 0	44256-10 KB x 4 and 41256-8 KB x 2 DIP
Bank 1	44256-10 KB x 4 and 41256-8 KB x 2 DIP
Bank 2	256-8 KB x 18 or 1 MB x 18 (JM1~JM3)
Bank 3	256-8 KB x 18 or 1 MB x 18 (JM2~JM4)



Installing memory modules into the sockets on the system board involves the following steps:



1. Locate the memory module sockets (Figure 3-1). Begin by inserting the first in the top socket (banks JM1 and JM3).
2. Figure 3-1 illustrates the correct orientation of the memory expansion module and the angle at which it should be held to insert. For each socket, the first memory expansion module must be inserted in the left-most slot (JM1) and the second memory expansion module in the right-hand slot (JM3).



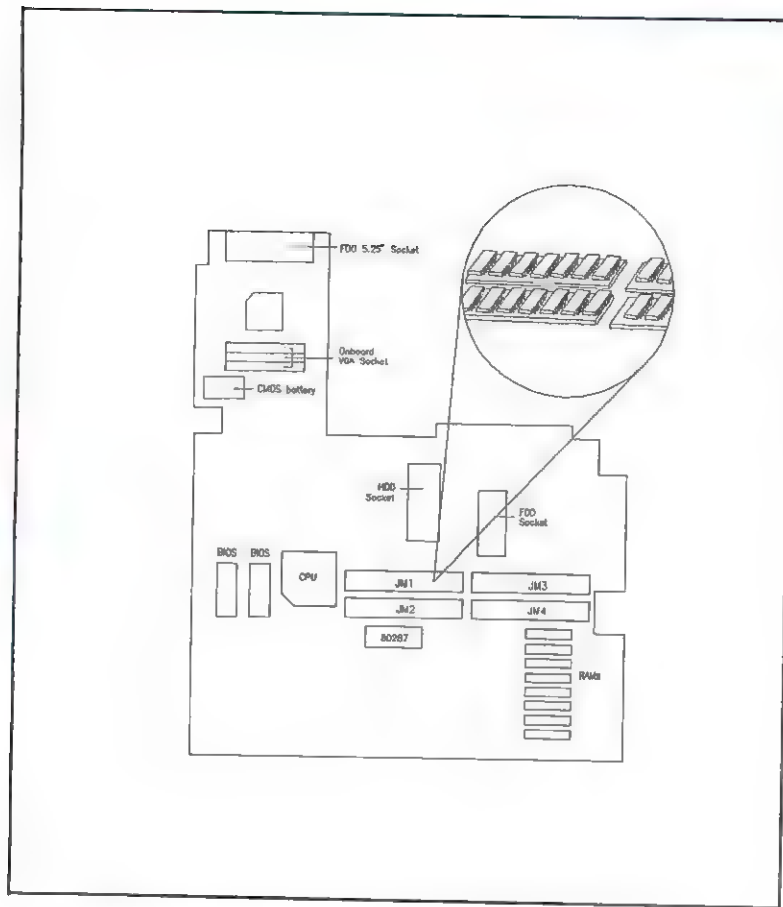

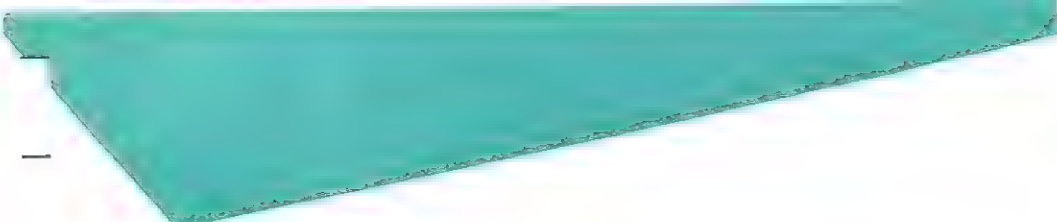

**Figure 3-1. Memory Expansion Module Sockets**

- 
- 
3. Slip a SIMM diagonally into the first empty slot of bank JM1, with the component side facing the RAMs. With the memory expansion module positioned correctly, insert the bottom edge of the module into the correct slot of the socket, pressing firmly while maintaining the angle of insertion.
  4. With the memory module correctly seated and held at each end, gently push the top edge toward the socket slot retaining clips until it snaps into place.
  5. Make sure the memory expansion module is seated correctly. If it isn't, gently spread the retaining clips just enough to permit the top edge of the module to be pulled away from the clips. Reseat the memory expansion module and repeat step 4 to complete installation.
  6. Follow steps 1 through 5 to install the remaining memory expansion module into the socket slots.

### **Installing a Numeric Coprocessor**

Socket U35 on the system board is available for a math coprocessor. The coprocessor must be a 6 (jumper P(1,2) installed) or (jumper P(2,3) installed) 12 MHz 80287.

To install the 80287 coprocessor, align the coprocessor chip pins with the inner pinholes on the socket (see Figure 3-2). Press the chip firmly down until it is properly seated. Be careful not to bend any pins.

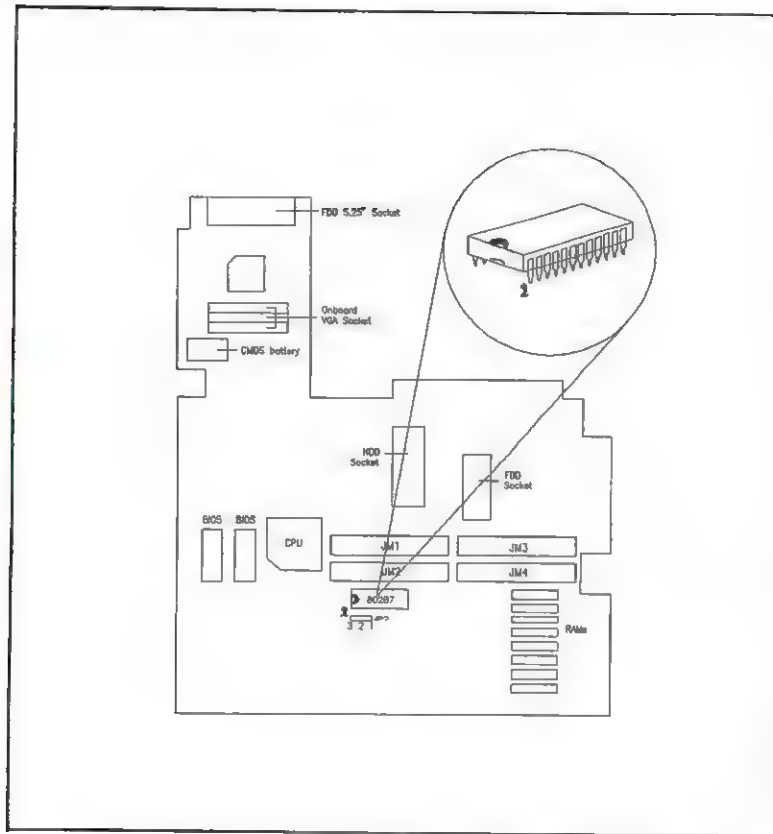

**Figure 3-2. Installing a Numeric Coprocessor**

## Installing and Removing Expansion Boards

The system contains one PC XT/AT-compatible expansion slot. See Figure 3-3 for the location of the slot on the system unit.

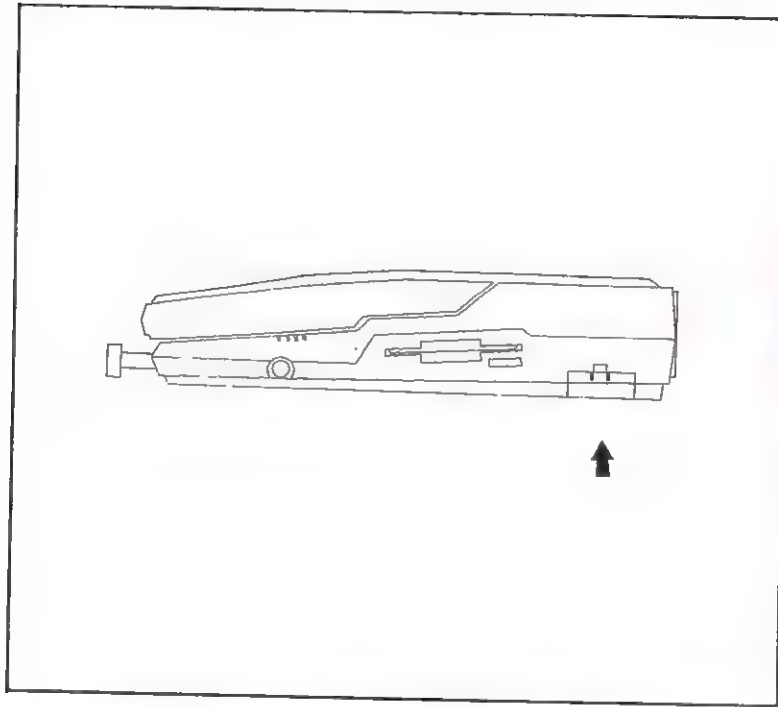
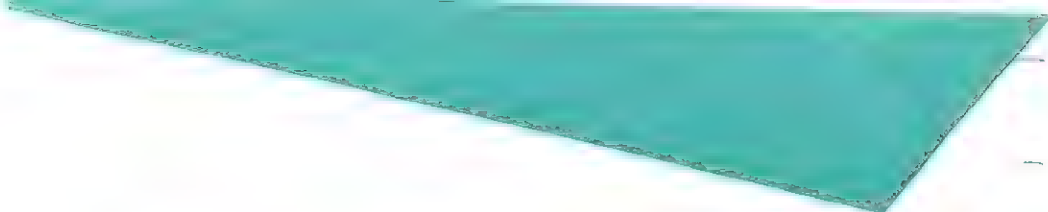

Figure 3-3. Location of the Expansion Slot



Expansion boards are extremely sensitive to electrostatic discharge (ESD) and always require careful handling. Install an expansion board using the following procedures.

1. Remove the half-sized expansion board from its wrapper, holding the board by the edges only. Avoid touching the board elements and the gold connectors.
2. Insert the board's connectors into the system board expansion slot by firmly pressing the board into the slot (in a horizontal motion) while holding the board by its side edge with the gold connector facing the system unit rear panel.
3. Align the hole in the board retaining bracket with the screw slot in the expansion slot frame.
4. Insert the screw (Figure 3-4) making sure that the bracket screw slot is pushed all the way against the screw before tightening.



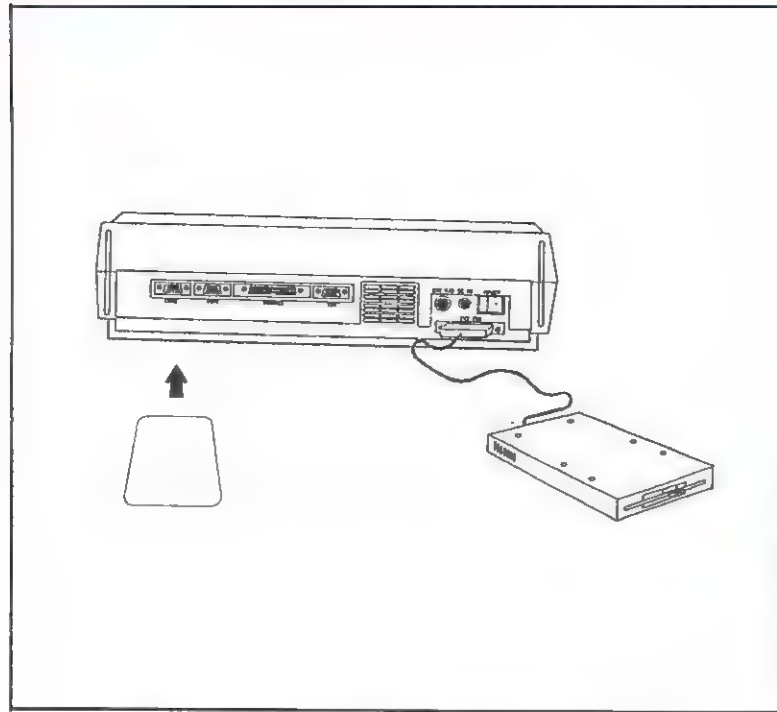

**Figure 3-4. Installing an Expansion Board**

## Installing the 5.25-inch Flexible-Disk Drive

1. Take out the 5.25-inch flexible-disk drive's chassis shipped with the system unit from the carrying bag. Be sure that the connecting screws are in the carrying bag. Remove the base plate of the 5.25-inch flexible-disk drive's chassis as shown below.

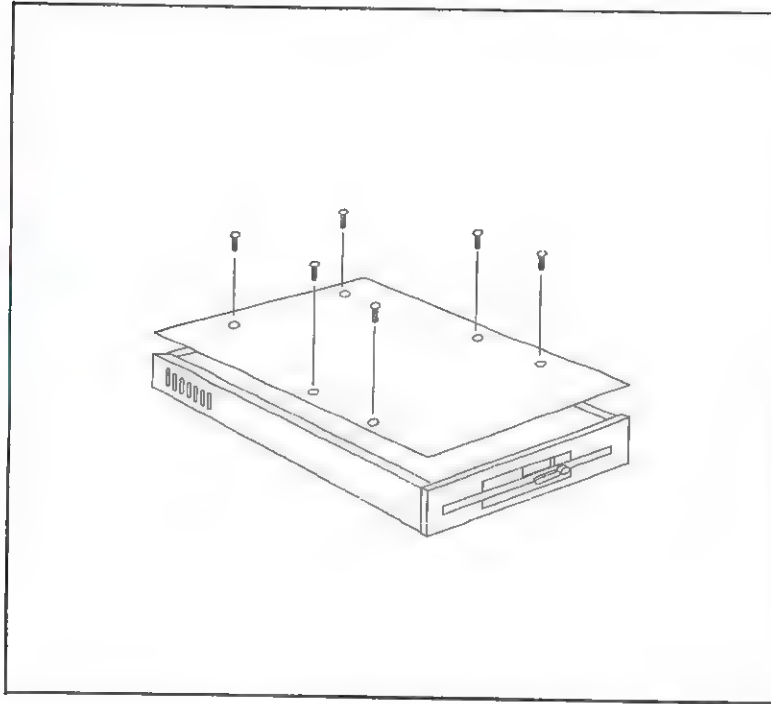
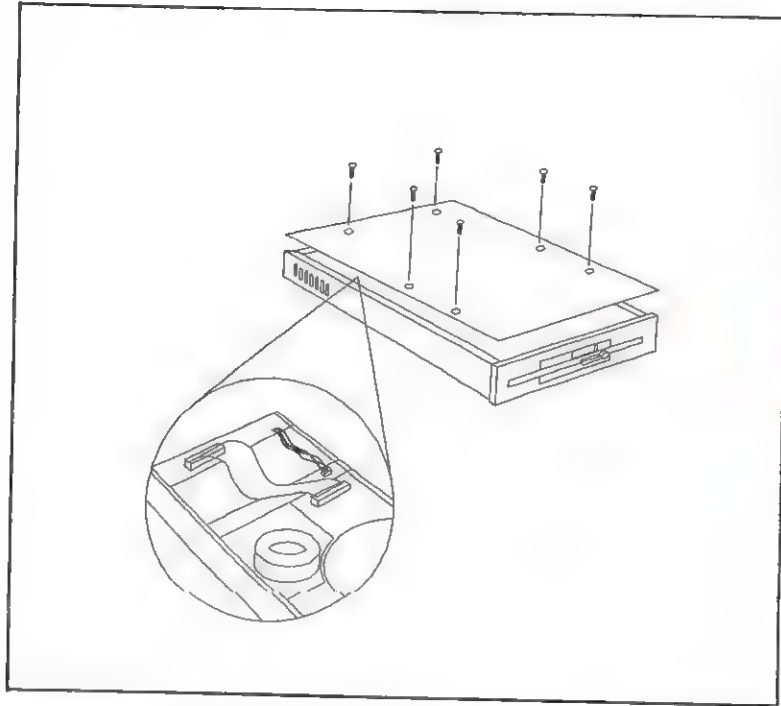

Figure 3-5. Removing the 5.25-inch Flexible-Disk Drive Chassis Base Plate

2. Remove the flexible-disk drive from its container and connect it to the chassis (see figure below). Connect the drive's cable to the cable in the chassis as shown below. Be sure that the 5-25-inch flexible disk drive is seated properly inside the chassis. Check the proper position of the flexible disk-drive in the chassis.



**Figure 3-6. Connecting the 5.25-inch Flexible-Disk Drive to its Chassis**



3. Fasten the connecting screws in the base plate of the flexible-disk drive as shown below. Set the flexible-disk drive (FDD) switch on the rear panel of the system unit to A (setting the 3.5-inch flexible disk drive to the default A setting). Your 5.25-inch flexible-disk drive can now be accessed as drive B.

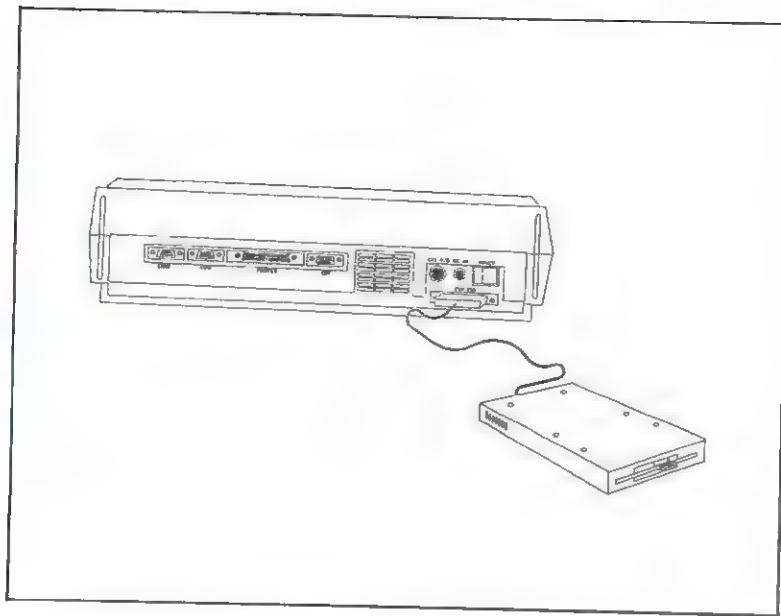

Figure 3-7. Installing the 5.25-inch Flexible-Disk Drive

### Setting the CPU Operating Speed

The default setting of your system speed is 20 MHz. The system's CPU automatically adjusts its operating speed while accessing diskettes, since some software packages (i.e., Game, or packages that use flexible disk protection method) may not operate correctly at 20 MHz. When you are using an external keyboard, follow the steps below in changing CPU speed.

To change the CPU speed to low speed of 10 MHz press:

<Ctrl> <Alt> - (minus sign)

To change the CPU speed to high speed of 20 MHz press:

<Ctrl> <Alt> + (plus sign)

When using the embedded laptop keyboard, use the Fn keys explained in the following section in changing CPU speed.



### Using Fn key

The Fn key located at the lower side of your laptop keyboard provides system's speed and LCD functions.

When booting the system, a menu showing all the Fn function key is displayed. You can then invoke the Fn function help menu by pressing:

Fnhelp

The file LVGAkeyb that contains the Fn function key usage is loaded. Shift and Ctrl are equivalent keys and used according to the type of keyboards you may have. Fn key is equivalent to pressing Ctrl and Alt or Shift and Alt. When Fn is pressed together with the other keys, it provide functions that are helpful when using your LCD screen.



The following table shows the functions of the Fn key when used together with the other keys.

**Table 3-2. Fn Key Function**

Keys	Function
Fn and +	Changes CPU speed to high
Fn and -	Changes CPU speed to low
Fn and PgUp	Selects page/interleave mode for memory access; press <Shift> + <Alt> + <+> when using an external keyboard
Fn and PgDn	Selects one wait state; press <Shift> + <Alt> + <-> when using an external keyboard



Keys	Function
Fn and Home	Selects the LCD screen; press Ctrl + Alt + L when using an external keyboard
Fn and End	Selects the external monitor; press Ctrl + Alt + O when using an external keyboard
Fn and I	Toggles background LCD screen from normal to inverse and vice versa
Fn and >	Shifts LCD screen to the right; press Ctrl + Alt + > for external keyboard
Fn and <	Shifts LCD screen to the left; press Ctrl + Alt + < for external keyboard
Fn and M	Returns LCD screen to centered position; press Ctrl + Alt + M for external keyboard

**Note:** The Fn help menu that comes with your fixed disk is updated with all the enhanced functions to fully maximize your LCD screen.

## Using Soft Switches

For non-English users, LVGAKEYB program enables the soft switches. This program should be installed in your fixed disk. Copy the LVGAKEYB.EXE program in your utility diskette to your fixed disk. Soft switches can be used by entering the following at the system C> prompt:

```
KEYB GR
LVGAKEYB
```

where GR represents German keyboard.

A German keyboard is installed after entering the above command. Make sure that the LVGAKEYB utility is present on the fixed disk. Each time a KEYB.COM program is executed, soft switches are disabled. Soft switches are again enabled when the LVGAKEYB program is executed. Add the above commands in your AUTOEXEC.BAT batch program for ease of use.

**Note:** Run the KEYB program first before the LVGAKEYB program, or else the system halts.

The table below lists the other soft switches for other keyboards.

**Table 3-3. Keyboard Codes**

<b>Keyboard Country</b>	<b>Codes</b>
Australia	US
Belgium	BE
Canada (Eng.)	US
Canada (Fr.)	CF
Denmark	DK
Finland	SU
France	FR
Germany	GR
Italy	IT

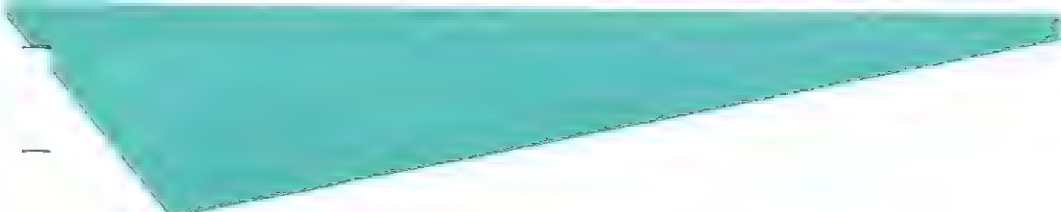

<b>Keyboard Country</b>	<b>Codes</b>
Latin America	LA
Netherlands	NL
Norway	NO
Portugal	PO
Spain	SP
Sweden	SV
Switzerland (Fr.)	SF
Switzerland	SG
United Kingdom	UK
United States	US





## Connecting Input/Output (I/O) Devices

The following I/O devices can be connected to the system unit: external monitor and keyboard, modem, mouse, and printer. Follow the procedures outlined below in connecting a monitor, a printer, a keyboard, and a mouse.

### Connecting an External Monitor



Connect the external monitor cable to the system's external monitor port located at the rear panel. Use the Bright and Contrast knob to adjust the screen display. For Multisync monitor with a 9-pin connector, a special 9-pin to 15-pin converter cable should be used.

### Connecting a Printer

1. Before connecting your printer, study your printer manual and confirm the printer type. Make sure that the printer power switch is set to off.
2. Connect the printer cable to the 25-pin parallel printer port located at the rear panel of the system unit. Ensure that the cable connector is well-seated in the interface port of the system.
3. Connect the printer to a power source.

## Connecting a Keyboard

Connect the external keyboard to the keyboard connector located at the rear panel of the system unit. Be sure to use the keyboard converter cable for proper connection.

## Connecting a Modem

Insert the modem or standalone modem card as shown in the figure below.

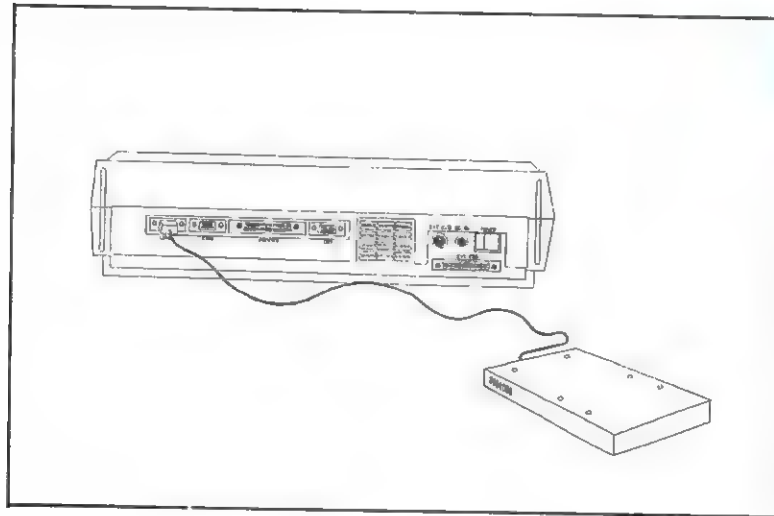

Figure 3-8. Connecting a Modem

## Connecting a Mouse

1. Turn off the power switch of the system and all the other peripherals connected to the system.
2. Connect the 9-pin connector of the mouse to the COM1 or COM2 serial port of the system unit.
3. Restore power to all peripherals and the system unit. Follow the software installation in the mouse manual.

## Connecting the System to a Power Outlet



The system operates at 115/230 VAC input power. Check the voltage source that is being used. To connect the power cord of the system unit, insert one end of the power cord to the system unit power socket, and to a grounded electric outlet.

## Starting Up the System

Turn on the system unit power switch. Make sure there is no drive protection card on the 3.5-inch flexible-disk drive. When the system boots up from your fixed disk, a C> prompt appears on your LCD display. You can reboot your system by pressing <Ctrl> <Alt> <Del> keys simultaneously. The 3600 runs some self-tests to check its components. After the self-tests, the screen displays BIOS (Basic Input/Output System) and system status messages. Refer to your MS-DOS User's Guide on how to install MS-DOS.

## Power-On Self Test (POST)

The Power-On Self Test (POST) runs automatically and checks the 80286 processor, the keyboard, the LCD display, system memory, and most peripheral devices connected to the system board each time the system is turned on or rebooted. The following procedure assumes a first-time power-up of the system.

If the system was previously operating satisfactorily, some of the following steps or indications will not apply.

1. Ensure that all cabling is secure and correct.
2. Set the system power switch to the ON position.
3. Apply power to the system. The POST will immediately begin operation. The first visual indication of the POST will be the keyboard status lights blinking on and off.
4. The POST memory test displays the amount of memory it has tested on the screen as the test progresses. POST takes from 3 to 15 seconds to complete, depending on the amount of extended memory present.
5. Adjust the display as necessary to obtain clear screen display.
6. When the POST is complete, the system will beep once if no configuration errors are detected.

**Note:** An A> prompt appears when there is a system diskette in your diskette drive. System diskette contains the COMMAND.COM and other hidden files of the MS-DOS program.

7. If configuration errors are detected, the system will beep twice and display a message.

POST is always invoked whenever the system power is turned off and then on again. However, a reboot, <Ctrl> <Alt> <Del>, causes a subset of the normal POST routine to be run. Once a system has been configured and the setup program run correctly, POST will complete, the operating system will be invoked, and the system will be ready for operation.

## Help Functions

A utility diskette is included with every LT3600. The HELP MENU file can be started as follows:



1. Your hard disk must be formatted and must include the 2 system files and the file "command.COM".
2. Insert the diskette in drive A: and type "LTLVGA.BAT" file. Copy the contents of the diskette to the hard disk.
3. Remove the diskette from drive A:
4. Boot from C: and run the batch file called "LTLVGA".

The following screen appears:

```
C:\>COPY CON: AUTOEXEC.BAT
ECHO OFF
PATH=C:\;%PATH%
PROMPT $PSG
REM Current uses U.S. standard keyboard.
REM Need run LVGAKEYB.COM hear to control LCD VGA card functions.
LVGAKEYB
REM Press [F6] key hear to save this file.

C:\>LVGAKEYB
```

This program controls the CCFT LCD VGA card functions and NEAT CHIPS LAP-AT speed. This HELP message uses U.S. standard keyboard. Press:-  
Fn and the following keys simultaneously:  
OR  
Ctrl or Shift with Alt and the following keys simultaneously:  
Fn and + or Ctrl with Alt and + changes Speed to high  
Fn and - or Ctrl with Alt and - changes Speed to low  
Fn and PgUp or Shift with Alt and + = Enable Page interleave  
Fn and PgDn or Shift with Alt and - = Disable Page interleave  
L or Fn and Home = Switch screen to LCD display  
O or Fn and End = Switch screen to external monitor  
I = Toggles LCD Text to inverse/normal  
> = Shifts screen to right < = Shifts screen to left  
M = Shifts screen to original display

## Programming LVGAKEYB.COM

See Appendix C for details of assembly language programming.

Notes:

Archived by:  
www.  
retrospace.  
net



Chapter 4  
RUNNING  
THE  
SETUP  
PROGRAM



Archived by:  
www.  
retrospace.  
net

---

## Running the Setup Program

This chapter explains how to configure your system using the Setup program.

### When does the System Prompt You to Run Setup?

The system prompts you to run SETUP under the following conditions:

- CMOS options not set.
- Display configuration mismatch.
- Memory size mismatch.
- Fixed-disk drive SETUP error.
- CMOS battery low.
- An additional fixed-disk presence is detected.

The following sections give details on how to run the SETUP program and list default values of the AMI (American Megatrends Inc.) BIOS SETUP program.



## Running the Setup Program

You need to run the Setup program in the following situations:

- To configure the system when the computer is turned on for the first time.
- To change the system configuration when adding or removing an option.
- To address a power on error message such as **Press F1 key to continue** message.



## Running the Setup Program

When the system powers up, the system does memory test and the following message is shown:

```
Stingray Rev 3/4, VGA BIOS Version 2.2 Preliminary 41
Copyright (c) Cirrus Logic Inc. 1989. All Rights Reserved.
```

```
286-BIOS 1989 American Megatrends Inc.
```

```
Press <Esc> to bypass memory test
```

```
Press <Del> if you want to run setup SETUP/EXTD-SET
```

```
(c) American Megatrends Inc.
ENET-1116-XXXXXX-K8
```

After the memory test, the system prompts you to press the DEL key for the Setup program.

The Setup program can be called during the start up of the system. The setup key is invoked by pressing:

```
<DEL>
```



The setup program does the following functions:

- Displays date, time, and two screens that list current values for system options.
- Allows you to accept current (default) values or enter different values for time, date, and system options.
- Shows detailed configuration options about each of the selections.
- Gives instructions on rebooting the system so that the new settings can take effect.

Since the setup program is permanently stored in ROM, a particular operating system or special setup diskette is not necessary to run the program.



**Note:**

Early versions of DOS allow you to invoke the setup program at any time even while running another program. Later versions of DOS, however, may install its own keyboard handler, as do not most other operating systems, in which case, the <DEL> key combination may not work. In this event, you can use the setup program only when prompted during system startup or by pressing <DEL> just before the short beep which signals the start of the boot process.

The setup program does not determine nor does it store the information specifying the presence or absence of the coprocessor. The coprocessor status is checked by the POST every time it is run. The setup program screen merely displays the coprocessor status.

Whenever a configuration change has been made to the system and power subsequently applied, the BIOS will generally generate the invalid configuration message. Pressing F1 after an invalid configuration message is displayed will cause the system to boot up with a minimum default system. As a consequence, the system will not be able to operate with its full potential.

If the small battery that maintains power for the CMOS chip has expired (usually after two years of use under normal conditions), all configuration information is lost and the system must be reconfigured.

**Note:** When you want to disable SETUP during the boot process, press the Ins key before powering up the system unit and release the Ins key only after the memory test has started. This method does not affect the CMOS Setup but cancels the execution of the Setup program.

The setup program can be invoked after the invalid configuration message by pressing F1 as instructed.

Thereafter, whenever the system is booted, POST always rechecks the stored setup information against the hardware configuration. If the data does not agree, the invalid configuration message will be displayed. Because the setup program is permanently stored in ROM, it is not necessary to have a particular operating system or to use a special setup diskette to run the program.

The setup program can be invoked at any time and its availability is not dependent upon having the invalid configuration message displayed.

The setup program can be run with or without an operating system present. To invoke the setup program, press <DEL>. A screen display similar to the example shown in Figure 4-1 appears.

When no key is pressed during system start up, the following is shown.

System Configuration (C) Copyright 1985-1989, American Megatrends Inc.	
Main Processor :80286	Base Memory Size: 640 KB
Numeric Processor:None	Ext. Memory Size: 0 KB
Floppy Drive A :1.44 MB, 3.5"	Hard Disk C:Type: 17
Floppy Drive B : None	Hard Disk D: Type: None
Display Type : VGA or EGA	Serial Port(s) : 3F8, 2F8
ROM-BIOS Date : 08/30/89	Parallel Port(s): 378
Bank 0/1 DRAM: 256 K DRAM	Bank 0/1 DRAM W/S: 1 W/S
Bank 2/3 DRAM: Disabled	Bank 2/3 DRAM W/S: 1 W/S
Memory Interleave: Enabled	Processor Clock:CLK21N
Shadow C0000h, 16K: Disabled	Bus Clock:CLK21N/2
Shadow C4000h, 16K: Disabled	DMA Clock:SCLK/2
Shadow F0000h, 64K: Disabled	

Extended memory size value of 384 KB is standard for normal mode and 0 KB for the BIOS and Shadow RAM default.

When <Del> key is pressed during the system's start-up, the CMOS setup program shows the following message:

```
EXIT FOR BOOT
RUN CMOS SETUP
RUN XCMOS SETUP
```

The cursor highlights the selections and the Up and Down arrow keys are used to select your option. Press the <Enter> key to validate your selection.



When you choose RUN CMOS SETUP, the following screen is shown:

CMOS SETUP (C) Copyright 1985-1989, American Megatrends Inc.								
Date (mm/date/year):	Tue, Oct 10 1989	Base memory size:	640 KB					
Time (hour/min/sec):	09: 15: 30	Ext. memory size:	0 KB					
Floppy Drive A :	1.44 MB, 3.5"	Numeric processor:	Not Installed					
Floppy Drive B :	Not Installed							
Sec Size		Cyln	Head	WPcom	LZone			
Hard disk C: type :	17	977	5	300	977			
17 41 MB								
Hard disk D: type :	Not Installed							
Primary display :	VGA or EGA							
Keyboard :	Installed	Sun	Mon	Tue	Wed	Thu	Fri	Sat
Onboard PRN option :	1	25	26	27	28	29	30	1
Scratch RAM option :	1	2	3	4	5	6	7	8
Onboard COM option :	0	9	10	11	12	13	14	15
LCD OFF timer value:	0	16	17	18	19	20	21	22
HDD OFF timer value:	0							
Month :	Jan, Feb, .....Dec	23	24	25	26	27	28	29
Date :	01, 02, 03, .....31	30	31	1	2	3	4	5
Year :	1901, 1902, .....2099							
Esc = Exit, ↓ → ↑ ← = Select, PgUp/PgDn = Modify								

4

**Figure 4-1. Typical Setup Screen**

The setup screen shows the current settings for the system. The actual display seen will be different from the example as it will reflect the exact individual configuration of your system. Two options, the base memory and expansion memory size, cannot be set.

When you are finish with the Setup program and the system reboots and displays the following message:

```
Chips NEAT Expanded Memory Manager 4.0 Version 1.5 (c) Copyright  
Chips and Technologies Inc. 1988, All Right Reserved
```

```
Expanded memory is not enabled.
```

```
C >
```

The setup screen lists the current options as maintained by the computer. To change any of these options, the cursor must be moved to that option using the Up Arrow and Down Arrow key. The cursor will move only to the options that can be changed.

To make a change, once an option has been selected, the correct value is selected by pressing the PgUp and PgDn key. Each time one of these keys is pressed, the setup program displays one of the possible values for that options. Two options, the base memory and extended memory, cannot be set using the PgUp Arrow and PgDn key. Instead, they require changes in the setup present in the extended CMOS setup program (NEAT.EXE) or XCMOS setup program.

When all options have been set, pressing the <Esc> key exits the setup program. The changes made will be saved but only the date and time information will take effect. The other changes cannot be effected until the system is rebooted.

Pressing the <Esc> key saves the setup information and reboots the computer, causing all setup changes to take effect immediately.



## Setting the Date and Time

When the Enter key is pressed, the setup program goes to the next screen display as shown and it will automatically reset the day of the week accordingly.

If the time is incorrect, enter the correct time by following the format in the screen. Follow through the other selection by pressing the Enter key.



## Setting Primary Display

The default setup is VGA or EGA and the following are the selections when you press the PgUp and PgDn keys:

Monochrome, Color 40 x 25  
VGA or EGA, Color 80 x 25, Not Installed

## Selecting Diskette Drive Types

The setup program maintains information about two diskette drives (floppy drive A and drive B). The drives include the embedded 3.5-inch diskette drive and the 5.25-inch external drive. If the information about either of these diskette drives is incorrect, use the Up or Down Arrow key to move the cursor to the appropriate diskette field.

Floppy drive A: 1.44 MB, 3.5-inch  
Floppy drive B: Not Installed

The diskette options are changed by pressing the PgUp and PgDn keys. The allowable diskette options are as follows:

360 KB 5.25-inch, 1.2 MB 5.25-inch  
720 KB 3.5-inch, 1.44 MB 3.5-inch, Not Installed

If only one flexible disk drive is installed, it will always be drive A. In this case, Drive B must be set to Not Installed. Check the A/B/P switch on the rear panel for the correct drive letter designation.



## Setting Fixed Disk Drive Types and Format

The setup program maintains drive type information for the fixed-disk drives.

Hard disk C: Type: 17  
Hard disk D: Type: None

If the drive type for either of these disks is incorrect, use the PgUp or PgDn key to change the default values. Generally, the drive type is provided by the disk drive vendor and should be given in the hardware reference manual for the hard disk drive.

However, in the event that the drive type is not known, the setup program contains a list of all supported fixed disk drive types and their major specifications.



By comparing this list with the specifications in the disk drive's hardware reference manual, it should be possible to determine the correct drive type.

## Setting Keyboard

The default setup is Installed and the following are the selections when you press the PgUp and PgDn keys:

Installed  
Not Installed

### Setting Onboard PRN Option

The default setup is 1 and the following are the selections when you press the PgUp and PgDn keys:

Onboard one parallel port using:-  
(1) = LPT1:                      (2) = LPT2:

### Setting Scratch RAM Option

The default setup is 1 and the following are the selections when you press the PgUp and PgDn keys:

If required, BIOS will use 256 bytes of RAM  
(1) : Using BIOS stack area at 0030:0000  
(2) : Reducing base memory size by 1 KB

### Setting Onboard COM Option

The default setup is 0 and the following are the selections when you press the PgUp and PgDn keys:

Onboard two serial ports using:-  
(0) = COM2:, COM1:              (1) = COM2:, COM3:  
(2) = COM4:, COM1:              (3) = COM4:, COM3:

### Setting Sleeping Mode Value

When the system is set to LCD OFF Timer and HDD OFF Timer values, the system enters "sleeping mode". This means that if you don't press any key under your set timer value, the LCD and HDD will be turned off by the BIOS. Less power will be consumed when you use if you use the LT3600 battery.

Just press any key should you want to wake the system up. The LCD will immediately turn on unlike the HDD wherein you have to wait for around 4-5 seconds.

### Setting LCD OFF Timer Value



If you don't press any key under LCD OFF Timer value, the LCD will turn off on its own. The mother board speed will go down to 3 MHz as well, unless you press any key that would wake the system up to its original speed. The default setup is 0 and the following are the selections when you press the PgUp and PgDn keys:

- (0) : LCD light always ON
- (1-7) : LCD light ON for 1,...7 minute

### Setting HDD OFF Timer Value

If the HDD is in "sleeping mode", you can't activate the HDD unless you access both HDD and FDD files. Activating period takes 4-5 seconds. The default setup is 0 and the following are the selections when you press the PgUp and PgDn keys:

- (0) : HDD power always ON
- (1-7) : HDD power ON for 1,...7 minutes

When all options have been set, pressing the <Esc> key exits the setup program. The changes made will be saved but only the date and time information will take effect. The other changes cannot be effected until the system is rebooted.

Pressing the <Esc> key saves the setup information and reboots the computer, causing all setup changes to take effect immediately.

**Note:** If you have a mistake in the Setup and the screen can not display any message after rebooting, just press the Ins key to clear the data that was in the Setup. When the power is switched on the system displays the default values.

## Extended Setup

Select the RUN XCMOS SETUP to use the extended CMOS setup. The screen message below is shown:

```
NEAT 286 Extended CMOS SETUP PROGRAM
Ver - 1.10, (C) 1988, American Megatrends Inc.

NEAT CHIPSET SETUP PROGRAM
MAIN MENU

EASY NEAT CHIPSET REGISTER SETUP
ADVANCED NEAT CHIPSET REGISTER SETUP
ENABLE/DISABLE VIDEO AND MAIN BIOS SHADOW
WRITE CMOS REGISTERS AND EXIT
DO NOT WRITE CMOS REGISTERS AND EXIT
```



When you choose any of the selection in the XCMOS setup, the message below is always shown. Press Enter key to confirm your selection.

NEAT 286 Extended CMOS SETUP PROGRAM  
Ver - 1.10, (C) 1988, American Megatrends Inc.

WARNING — IMPROPER USE OF THE SETUP MAY CAUSE THE SYSTEM  
TO FAIL NORMAL OPERATIONS!

IF THE SYSTEM FAILS, PRESS AND HOLD THE <INS> KEY,  
AND TURN THE MACHINE OFF AND THEN ON !

RELEASE THE <INS> KEY AFTER MEMORY TEST STARTS !

HIT <ESC> TO STOP NOW!  
HIT <ENTER> TO CONTINUE!

4

Selecting the EASY NEAT CHIPSET REGISTER SETUP shows the screen message below (BIOS default values):

NEAT 286 Extended CMOS SETUP PROGRAM			
Ver - 1.10, (C) 1988, American Megatrends Inc.			
Memory Configuration			
Bank	Enabled/Disabled	DRAM Type	Waitstate
0	Enabled	256 K	1 Wait state
1	Enabled	256 K	1 Wait state
2	Disabled		1 Wait state
3	Disabled		1 Wait state
Clock Sources Selected			ZERO WAIT STATE
Processor Clock	Bus Clock	DMA Clock	ONE WAIT STATE
CLK2IN	CLK2IN/2	SCLK/2	MOVE BAR - <PgUp/PgDn>
			CHANGE WINDOWS
			EXIT - <ESC>
Shadow RAM/Interleave			
BIOS Shadow	Video Shadow		Memory
F0000h, 64K	C0000h, 16K	C4000h, 16K	Interleave
Disabled	Disabled	Disabled	Disabled

Selecting the EASY NEAT CHIPSET REGISTER SETUP shows the screen message below (Normal mode default values):

NEAT 286 Extended CMOS SETUP PROGRAM			
Ver - 1.10, (C) 1988, American Megatrends Inc.			
	Memory Configuration		
Bank	Enabled/Disabled	DRAM Type	Waitstate
0	Enabled	256 K	1 Wait state
1	Enabled	256 K	1 Wait state
2	Disabled		1 Wait state
3	Disabled		1 Wait state
Clock Sources Selected		ZERO WAIT STATE	
Processor Clock	Bus Clock	DMA Clock	ONE WAIT STATE
CLK2IN	CLK2IN/2	SCLK/2	MOVE BAR - <PgUp/PgDn>
			CHANGE WINDOWS
			EXIT - <ESC>
	Shadow RAM/Interleave		
BIOS Shadow	Video Shadow	Memory	
F0000h, 64K	C0000h, 16K	C4000h, 16K	Interleave
Disabled	Disabled	Disabled	Enabled

The cursor highlights the selections and the Up and Down arrow keys are used to select your option. Press the <Enter> key to validate your selection.

The setup screen shows the current settings for the system. The actual display seen will be different from the example as it will reflect the exact individual configuration of your system.

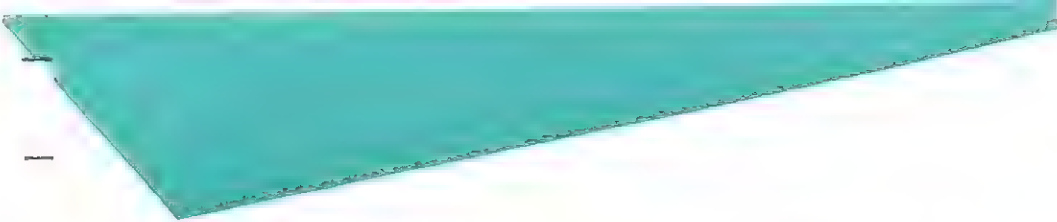

The setup screen lists the current options as maintained by the computer. To change any of these options, the cursor must be moved to that option using the Left and Right arrow keys. The cursor will move only to the options that can be changed.

To make a change, once an option has been selected, the correct value is selected by pressing the PgUp and PgDn key. Each time one of these keys is pressed, the setup program displays one of the possible values for that options.

## **Easy NEAT Chipset Register Setup**

### **Memory Configurations**

The BIOS displays the memory configuration of the system board by showing which banks are enabled and what type of DRAM is being used.

The user can set the wait state for all RAM banks at either zero or one wait state. Care must be exercised when choosing a wait state for your system since onboard memory must run at high speed to facilitate the absence of a wait state to synchronize operations.

## Clock Settings

The user can set the following clocks as necessary:

- Processor clock
- Bus clock
- DMA clock

### Processor Clock

The Processor clock can be set as the Bus clock, or as CLK2IN. CLK2IN is the input clock frequency which the processor normally runs at. The Bus clock is the clock for AT bus operation. The default value is CLK2IN.



### Bus clock

The Bus clock can have one of the following three settings:

- CLK2IN/2 (half of CLK2IN frequency)
- CLK2IN
- ATCLK (the clock associated with the AT bus).

The default value is CLK2IN/2. Care should be exercised in setting the bus clock speed. If the processor clock and bus clock are derived from the same source, problems could arise.

### Direct Memory Access Clock

The Direct Memory Access (DMA) clock has two settings listed below:

- SYSCLK (AT system clock maintains AT I/O timing)
- SYSCLK/2

### Shadow RAM and Memory Interleave

Enable the Shadow RAM using the following ROM areas:

- F0000h segment - 64 KB

**Note:**

You can't enable the VGA BIOS (C0000h~C7FFF) in this computer. Interleaved memory mode can be enabled when 2 or 4 banks of memory are enabled on the motherboard. If one sets the Interleave on with only 1 or 3 banks of memory, the BIOS will ignore the setting while booting up.



## Advanced NEAT Chipset Register Setup

### Setting 82C206 - Clock and Wait States Control

Using the AMI Extended Setup, the user can set only the 01h register on the 82C206. This register sets various wait states and clocks.

#### Setting XIOR/XIOW Wait State

Bits 7 and 6 set the XIOR/XIOW wait state. If high speed CPUs are used, this wait state need to be set. The following settings are possible:

- 00 - 1 I/O wait state
- 01 - 2 I/O wait states
- 10 - 3 I/O wait states
- 11 - 4 I/O wait states

#### Setting 16 - Bit DMA Wait State

Bits 5 and 4 set the 16-bit DMA wait state. The following settings are possible:

- 00 - 1 DMA wait state
- 01 - 2 DMA wait states
- 10 - 3 DMA wait states
- 11 - 4 DMA wait states

### Setting 8 - Bit DMA Wait State

Bits 3 and 22 set the 16-bit DMA wait state. The following settings are possible:

- 00 - 1 DMA wait state
- 01 - 2 DMA wait states
- 10 - 3 DMA wait states
- 11 - 4 DMA wait states

### Setting the EMS bit

Bit 1 sets the EMS bit.

### Setting the DMA clock

Bit 0 sets the DMA clock with the following options:

- 0 - DMA clock = SCLK/2
- 1 - DMA clock = SCLK/2



### Setting the Version Register - RB0 (64h index) 82C212

The version register simply controls the type of memory controller being used and gives the version number. Bit 7 is the NEAT memory controller identifier and a zero in this bit corresponds to the 82C212. Bits 5 and 6 indicate the revision number, 00 being the initial revision number. Bits 4 through 0 are reserved.

### Setting the ROM Configuration Register - RB1 (65h index)

Bits 7 through 4 are the shadow RAM write protections in 64K segments.



Bit	Addresses
4	F0000h~FFFFFFh
5	E0000h~EFFFFFFh
6	D0000h~DFFFFFFh
7	C0000h~CFFFFFFh

A one in any of these bits corresponds to Read only protection, and a zero corresponds to Read/Write capability for that particular series of addresses.

The default value for bits 7 through 4 is 1, making these viable storage areas for shadowed information. Bits 3 through 0 are the ROM enable/disable in 64K segments for shadowing.

Bit	Addresses
0	F0000h~FFFFFFh
1	E0000h~EFFFFFFh
2	D0000h~DFFFFFFh
3	C0000h~CFFFFFFh

A one in any of these bits corresponds to ROM being disabled (shadow RAM is enabled by default). Bits 3 through 1 have a default setting of 1 but the default setting for corresponding to the 0th bit is where the BIOS is stored. The ROM is +enabled here to keep the integrity of the BIOS.

#### Setting the Memory Enable-1 Register - RB2 (66h index)

Bit 7 corresponds to the address map for the RAM in the 512K to 640K area. A zero indicates that the RAM is on an I/O channel, and a 1 indicates that the RAM is on the system board. Bit 6 denotes the memory status from 256K to 512K. A zero indicates that the RAM is on the system board and a 1 indicates that the memory is attached via the AT-bus.

Bit 5 denotes the memory status from 0 K to 256 K, with 0 and 1 meaning the same as in the 256 K to 512 K case. Bits 4 through 0 are reserved. The default settings for the bits are 1 for bit 7, 0 for bit 6, 0 for bit 5 indicating that all memory between 0 KB to 640 KB is on the system board.

## Setting the Memory Enable-2 Register - RB3 (67h index)

This register enables or disables the shadow RAM at various memory locations. A zero denotes that shadowing is enabled. The default is zero. The following table lists the addresses of each bits.

Bit	Addresses
7	BC000h~BFFFFh
6	B8000h~BBFFFh
5	B4000h~B7FFFh
4	B0000h~B3FFFh
3	AC000h~AFFFFh
2	A8000h~ABFFFh
1	A4000h~A7FFFh
0	A0000h~A3FFFh



### Setting the Memory Enable-3 Register - RB4 (68h index)

This bit functions as the RB3 register but has a different memory addresses. The following table lists the addresses.

Bit	Addresses
7	DC000h~DFFFFh
6	D8000h~DBFFFh
5	D4000h~D7FFFh
4	D0000h~D3FFFh
3	CC000h~CFFFFh
2	C8000h~CBFFFh
1	C4000h~C7FFFh
0	C0000h~C3FFFh

### Setting the Memory Enable-4 Register - RB5 (69h index)

This bit functions as the RB4 register but has a different memory addresses. The following table lists the addresses.

Bit	Addresses
7	FC000h~FFFFh
6	F8000h~FBFFFh
5	F4000h~F7FFFh
4	F0000h~F3FFFh
3	EC000h~EFFFFh
2	E8000h~EBFFFh
1	E4000h~E7FFFh
0	E0000h~E3FFFh

4

### Setting the Bank 0/1 Enable Register - RB6 (6Ah index)

Bits 7 and 6 contain information about the DRAM types used on the system board. The following table lists the DRAM types associated with the combinations of bit 7 and 6.

Bit		Memory
7	6	
0	0	Disabled
0	1	256 and 64 Kbit DRAMs (640 KB combinations)
1	0	256 Kbit DRAMs (default)
1	0	1 M DRAMs

Bit 5 indicates the number of RAM banks used. A zero corresponds to one bank of non-interleaved memory, and a one corresponds to two banks must be present to allow for interleaving. Bit 4 through 0 are reserved.



### Setting the DRAM Configuration Register - RB7 (6Bh index)

This register allows the user to set the wait states of the EMS, RAM and the ROM as well as enable the EMS. Bit 7 is the page/interleaved mode enable. A zero disables the page/interleaved mode, allowing useage of normal mode for the DRAMs (default). A one enables page/interleaved mode for the DRAMs. BIOS enables Interleaved mode only if there are two or four banks of onboard memory.



Bit 6 is the 640-KB to 1-MB RAM relocation bit. A zero does not relocate local RAM. A one (default) relocates local RAM from 0A0000h~0FFFFFFh to 1000000h~15FFFFFFh (for 1 MB RAM only). Relocation is not possible when using Shadow RAM because the same memory is used for Shadow RAM operation. If your expansion memory is above 1 MB, you can't relocate your memory from 0A000h~0FFFFFFh to 1000000h~15FFFFFFh.

Bit 5 is associated with the RAM wait states. When set to 0, accesses have 0 wait states. When set to 1 (default), accesses will have 1 wait state.

Bit 4 is the EMS enable bit. When set to 0, EMS is disabled (default), enabled when set to 1.



Bits 3 and 2 index the EMS memory accesses wait states, the following table lists the allowable combinations:

Bit		Wait State
3	2	
0	0	0
0	1	1
1	0	2 (default)
1	1	Reserved

Bits 1 and 0 are the ROM access wait state controllers. The bit values corresponding to the various wait states are shown below.

Bit		Wait State
1	0	
0	0	0
0	1	1
1	0	2
1	1	3 (default)



### Setting the Enable Register - RB8 (6Ch index)

Bits 7 and 6 are the bits that indicate the local DRAM types that are being used for banks 2 and 3. The bit values are shown below.

Bit		Wait State
7	6	
0	0	none (default)
0	1	Reserved
1	0	256 Kbit
1	1	1 Mbit

Bit 5 corresponds to the number of local RAM banks that are to be used. A 0 means that one bank is used in the non-interleaved mode (default). A 1 means that two banks are being used in the Interleaved mode.

4

Bit 4 defines the interleave type. Bits 3 through 0 are reserved.

### Setting the Base Address Register - RB9 (6CD index)

Bits 7 through 4 select the expanded memory base addresses. They are encoded as follows, with unused combinations being reserved.

Bits				EMS Base Address
7	6	5	4	
0	0	0	0	C000h, C400h, C800h, CC00h
0	0	0	1	C400h, C800h, CC00h, D000h
0	0	1	0	C800h, CC00h, D000h, D400h
0	0	1	1	CC00h, D000h, D400h, D800h
0	1	0	0	D000h, D400h, D800h, DC00h
0	1	0	1	D400h, D800h, DC00h, E000h
0	1	1	0	D800h, DC00h, E000h, E400h
0	1	1	1	DC00h, E000h, E400h, E800h
1	0	0	0	E000h, E400h, E800h, EC00h



**Setting the EMS Address Extension Register - RB10 (6Eh index)**

Bits 7 and 6 are the Page 0 address extension bits. The following combinations are valid:

Bit		Block of EMS Memory
7	6	
0	0	1 MB to 2 MB
0	1	2 MB to 4 MB
1	0	4 MB to 6 MB
1	1	6 MB to 8 MB



Bits 5 and 4 are the Page 1 address extension bits. The following combinations are valid:

Bit		Block of EMS Memory
5	4	
0	0	1 MB to 2 MB
0	1	2 MB to 4 MB
1	0	4 MB to 6 MB
1	1	6 MB to 8 MB

Bits 3 and 2 are the Page 2 address extension bits. The following combinations are valid:

Bit		Block of EMS Memory
3	2	
0	0	1 MB to 2 MB
0	1	2 MB to 4 MB
1	0	4 MB to 6 MB
1	1	6 MB to 8 MB

Bits 1 and 0 are the Page 3 address extension bits. The following combinations are valid:

Bit		Block of EMS Memory
3	2	
0	0	1 MB to 2 MB
0	1	2 MB to 4 MB
1	0	4 MB to 6 MB
1	1	6 MB to 8 MB

Setting the Miscellaneous Register - RB12 (6Fh index)

Bit			EMS Memory Size
7	6	5	
0	0	0	0.5 MB
0	0	1	1.0 MB
0	1	0	2.0 MB
0	1	1	3.0 MB
1	0	0	4.0 MB
1	0	1	5.0 MB
1	1	0	6.0 MB
1	1	1	7.0 MB

4

Selecting the **ADVANCED NEAT CHIPSET REGISTER SETUP** displays the following screen message as BIOS default values:

Extended CMOS SETUP PROGRAM Ver - 1.50, (C) 1988, American Megatrends Inc.	
Bits 7-0	Go to Prev/Next Register Go to Prev/Next Entry - Scroll Bit value - PgUp/PgDn Return to MAIN MENU - <ESC>
82C211	ROM Configuration Register RB1
60h -> 0 0 0 0 R 0 R 0	ROM Configuration Register RB1
61h -> 1 1 00 01 10	ROM at F0000h to FFFFh 1 = ROM Disabled 0 = ROM Enabled
62h -> RR 10 11 00	
82C212B	
64h -> 0 01 RRRRR	
65h -> 0 0 0 0 1 1 1 0	
66h -> 1 0 0 RRRRR	
67h -> 0 0 0 0 0 0 0 0	
68h -> 0 0 0 0 0 0 0 0	
69h -> 0 0 0 0 0 0 0 0	
6Ah -> 1 0 0 RRRRR	
6Bh -> 0 1 1 0 1 0 1 1	
6Ch -> 0 0 0 1 RRRR	
6Dh -> 0100 0000	
6Eh -> 0 0 0 0 0 0 0 0	
6Fh -> 0 0 0 0 R 1 1 R	
82C206	
60h -> 1 1 0 0 0 0 0 0	



Selecting the **ADVANCED NEAT CHIPSET REGISTER SETUP** displays the following screen message as **Normal mode** default values:

Extended CMOS SETUP PROGRAM Ver.- 1.50, (C) 1988, American Megatrends Inc.	
Bits 7-0	
82C211	60h -> 0 0 0 0 R 0 R 0
	61h -> 1 1 00 01 10
	62h -> RR 11 11 00
82C212B	64h -> 0 01 RRRRR
	65h -> 0 0 0 0 1 1 1 0
	66h -> 1 RRRRRR
	67h -> 0 0 0 0 0 0 0 0
	68h -> 0 0 0 0 0 0 0 0
	69h -> 0 0 0 0 0 0 0 0
	6Ah -> 1 0 1 RRRRR
	6Bh -> 1 1 0 0 1 0 1 1
	6Ch -> 0 0 0 1 RRRRR
	6Dh -> 0100 0000
	6Eh -> 0 0 0 0 0 0 0 0
	6Fh -> 0 0 0 R R 1 1 R
82C206	60h -> 1 1 0 0 0 0 0 0
	Go to Prev/Next Register
	Go to Prev/Next Entry -
	Scroll Bit value
	- PgUp/PgDn
	Return to MAIN MENU
	- <ESC>
	ROM Configuration
	Register RB1
	ROM Configuration
	Register RB1
	ROM at F0000h to FFFFFh
	1 = ROM Disabled
	0 = ROM Enabled

Selecting the **ADVANCED NEAT CHIPSET REGISTER SETUP** displays the following screen message as **Shadow RAM** mode default values:

Extended CMOS SETUP PROGRAM Ver - 1.50, (C) 1988, American Megatrends Inc.	
<b>Bits 7-0</b>	
<b>82C211</b>	60h -> 0 0 0 0 R 0 R 0 61h -> 1 1 00 01 10  62h -> RR 11 11 00
<b>82C212B</b>	64h -> 0 01 RRRRR 65h -> 0 0 0 0 1 1 1 0 66h -> 1 0 0 RRRRR  67h -> 0 0 0 0 0 0 0 0 68h -> 0 0 0 0 0 0 0 0 69h -> 0 0 0 0 0 0 0 0 6Ah -> 1 0 1 RRRRR 6Bh -> 1 0 0 0 1 0 1 1 6Ch -> 0 0 0 0 RRRR 6Dh -> 0100 0000 6Eh -> 0 0 0 0 0 0 0 0 6Fh -> 0 0 0 0 R 1 1 R
<b>82C206</b>	60h -> 1 1 0 0 0 0 0 0
	Go to Prev/Next Register Go to Prev/Next Entry - Scroll Bit value - PgUp/PgDn Return to MAIN MENU - <ESC>
	ROM Configuration Register RB1
	ROM Configuration Register RB1
	ROM at F0000h to FFFFFh 1 = ROM Disabled 0 = ROM Enabled



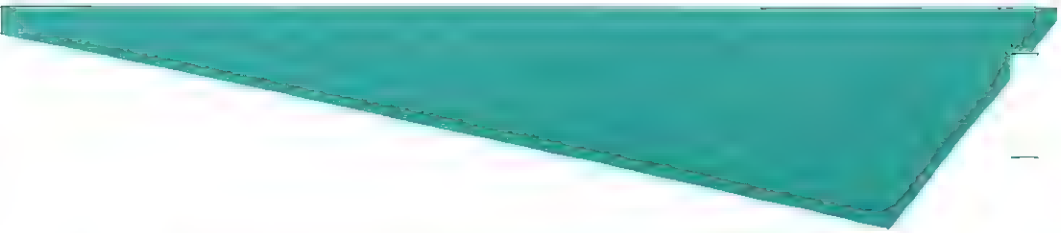

The values of the bits have already been changed to its correct values to match the configuration. You have to change the values depending on your system's configuration (i.e., memory size of 2 MB allows an expanded memory of 1 MB).

R means reserved bit and should not be altered.

Set the memory bit values according to the DRAM chips installed in your system memory board. The following configuration brings your system EMS range up to 2 MB.

Use the arrow keys to move the cursor to the bit value(s) and PgUp and PgDn keys to change the bit value(s). When all the bit values has been set correctly, enter the Esc key to quit this sub-menu. The main menu will be shown and select WRITE CMOS REGISTERS AND EXIT and then press the Enter key. You have now configured the system for EMM.



**Note:**

Run the CMOS Setup again after changing the EXTD-SETUP, otherwise the message **CMOS Memory Size Mismatch** appears.

### Notes On Extended CMOS Setup:

1. Bit 6 (6Bh) of the 82C212B register should be set to 0 (do not relocate RAM) for a memory size of 1 MB, making the EMS size = 0.
2. Bit 4 of the 60h register should be set to 1 to change the speed to 6.23 (low speed) MHz and 0 for 20 MHz.
3. The following are the functions of each registers:
  - 60h -> PROCCLK register
  - 61h -> Wait state control register
  - 62h -> System clock select register
  - 64h -> Not used
  - 65h -> Shadow RAM at C0000h~CFFFFh
  - 66h -> Address map for RAM in 512~640 K
  - 67h -> Shadow RAM at BC000h~BFFFFh
  - 68h -> Shadow RAM at DC000h~DFFFFh
  - 69h -> Shadow RAM at FC000h~FFFFFh
  - 6Ah -> Bank 0/1 Enable register
  - 6Bh -> Page/Interleave mode enable
  - 6Ch -> Bank 2/3 DRAM type
  - 6Dh -> EMS base address register
  - 6Eh -> EMS address extension register
  - 6Fh -> Sets EMS memory size
  - 01h -> Clock and waitstate control

Selecting the **ENABLE/DISABLE VIDEO AND MAIN BIOS SHADOW SETUP** displays the following screen message as default values:

Extended CMOS SETUP PROGRAM Ver - 1.50, (C) 1988, American Megatrends Inc.	
MAIN BIOS SHADOW AT F0000h, 64K --> 0	Go to Prev/Next Entry Scroll Bit value - PgUp/PgDn Return to MAIN MENU --<Esc>
VIDEO BIOS SHADOW AT C0000h, 16K --> 0	
VIDEO BIOS SHADOW AT C4000h, 16K --> 0	
	MAIN BIOS SHADOW AT F0000h, 64 K 1 = SHADOW ENABLE 0 = SHADOW DISABLE

**Note:** Video BIOS Shadow feature is not available in this laptop.

## Setting Memory Type and Size

1. Change bit 7 of register 66h is the memory enable - 1 register RB2. The address map for RAM in 512K to 640K area can be changed using the following valid selections:
  - 0 = RAM on I/O channel
  - 1 = RAM on System board
2. Change the DRAM type using register 6Ah, bit 7 and 6. Bank 0/1 Enable register RB6 have the following valid values (bank 0/1 DRAM types):
  - 00 = Disabled
  - 01 = 256K and 64K combination
  - 10 = 256K DRAMs
  - 11 = 1M bit DRAMs
3. Change the number of RAM banks used by changing bit 5 of register 6Ah (bank 0/1 Enable Register RB6).
  - 0 = 1 bank non interleaved
  - 1 = 2 banks
4. Set bank 2/3 DRAM types by changing the values of bit 7 and 6 of register 6Ch using the selections below:
  - 00 = None
  - 01 = Reserved
  - 10 = 256K bit
  - 11 = 1M bit
5. Set bit 3 of register 6Ch which indicates the number of banks used in bank 2/3.
  - 0 = 1 Banks in non interleaved mode
  - 1 = 2 Banks

6. Use bit 6 of register 6Bh to relocate DRAMs at 640K to above 1 MB.

**0 = Do not relocate RAM**

**1 = Relocate 80000h~FFFFFh to 100000h~11FFFFh.**

**Note:** *When you have no other RAM above 1 M, this function relocates the DRAM address between 640K~1024K to be changed to 1M~1M + 384K. For memory above 1M, disable this function to avoid conflict with other address areas.*

### Setting Zero Wait States

**4**

**Note:** Be sure that you have at least two banks of RAM in your main board in order to interleave or have a faster memory access time. Zero wait states is invalid when your number of banks is only one.

1. Change the RAM access wait states by using bit 5 of register 6Bh. The following are valid selections:
  - 0 = Zero wait states
  - 1 = One wait state
2. Change the Page/interleave mode enable by using bit 7 of register 6Bh. The following are valid selections:
  - 0 = DRAMs used in normal mode .
  - 1 = DRAMs used in page/interleaved

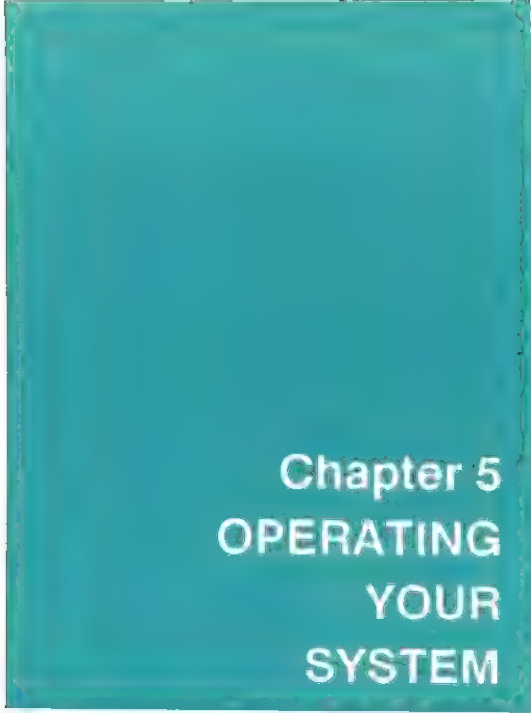

Chapter 5  
OPERATING  
YOUR  
SYSTEM





## Operating Your System

This chapter explains the use of the software utilities.

### System Software Utilities

All systems are shipped with utilities diskette. These diskette contain software utilities that allow you to take advantage of the special features of your laptop. NEATEMM.SYS — The NEAT Extended Memory Manager is a utility that allows application programs that can use expanded memory, as defined by Lotus/Intel /Microsoft (LIM) Expanded Memory Specification (EMS) standard version 3.2, to access memory beyond the 640 KB limit imposed by MS-DOS.

EAGLE.EXE — This setup utility program allows you to configure your LCD screen.

P41\_C000.SYS — This utility supports DOS device driver video function.

CRT.COM — This utility switches the screen from LCD to CRT.

LCD.COM — This utility switches the screen from CRT to LCD.

**Note:** Only one NEATEMM device driver can be loaded into the memory when you start the computer. An error occurs if an attempt is made to load more than one copy.





## ROM-Based

Included in the system board ROM BIOS is a setup program that stores system configuration information. This information takes effect when the system is rebooted.

Setup is a multi-function program that:

- Configures the system
- Performs the physical format of the fixed disk
- Parks the fixed disk drive heads in a safe position when you need to move the fixed disk.

The setup is invoked by pressing <Ctrl> <Alt> S simultaneously. Refer to Chapter 4 for a detailed discussion on the setup program.





## NEATEMM Utility

The system has a NEATEMM.SYS program installed in the fixed disk. This program installs the EMS (Expanded Memory System) function of the system for memory size greater than 1 MB.

To install this utility, add the following commands in your CONFIG.SYS file:

```
device =\neatemm.sys
```

This EMS (Expanded Memory Specification) version 4.0 device driver is a standard MS-DOS device driver that gets loaded at boot time by the CONFIG.SYS file. Without anything else included in this command line, the EMS driver will get loaded with the default hardware values of the I/O address that enables the EMS and the memory address used for EMS paging. These default values are dependent on the NEAT implementation of EMS.



To change these default values and add a few extra features at the same time, the EMS device driver command line should be entered as follows:

```
device = neatem.sys -Ix -my -pzz -d
```

where:

**I** = I/O address to enable EMS page

**x** = 0 ==> 208h

      = 1 ==> 218h

      = 5 ==> 258h

      = 6 ==> 268h

      = A ==> 2A8h

      = B ==> 2B8h

      = E ==> 2E8h

**m** = page frame address (address of 64 K window)

**y** = 1 ==> C000h

**y** = 2 ==> C400h

**y** = 3 ==> C800h

**y** = 4 ==> CC00h

**y** = 5 ==> D000h

**p** = maximum number of open processes  
(defaults to 64)

**zz** = number of processes (1~128)

**d** = enable EMS diagnostics

5

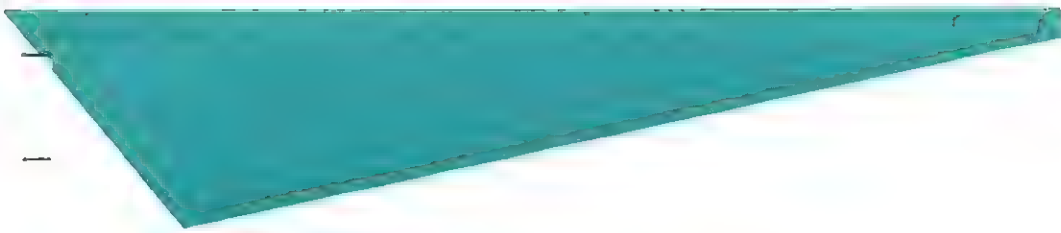

The command line parameters can be in either upper or lower case. When the EMS driver is first executed, a title and copyright notice appears on the screen as:

```
EMS Expanded Memory Device Driver Ver. 4.0  
Copyright (c) Chips and Technologies Inc., 1987
```

When the EMS driver detects that a previous EMS driver has already been loaded, the following screen message is displayed:

```
An Expanded Memory Manager has already been installed.
```

The EMS driver will not be loaded into the system.



When the EMS driver gets loaded by MS-DOS, an internal check is done on the EMS configuration in the hardware. If the driver detects any conflicts that would cause EMS not to function properly, the message below is shown:

The EMS setup has been incorrectly specified, No EMS is available.

The EMS driver will be disabled.

When the EMS hardware is configured properly and the I/O address is overridden by the command line parameter, the screen below appears:

The EMS I/O address has been changed.

When the EMS page frame address is being overridden from the command line, the following message appears:

The EMS Frame Segment has been changed.

When the diagnostics option is selected, the following screen message appears:

testing EMS Expanded Memory Page Numer: NNN

The NNN represents the page number currently under test. When the diagnostics fail, the EMS is disabled and the following screen message appears:

Expanded Memory FAILED diagnostics test.

When the diagnostics pass, or when it is not specified on the command line, the EMS driver is loaded correctly and EMS is enabled. The final screen message below appears:

There are xxx pages, or yyyy Kbytes of EMS Expanded Memory on the system.

The system can now be used to support Lotus/Intel/Microsoft (LIM) EMS 4.0 in the same manner as standard EMS boards.

## **P41\_C000.SYS**

When CONFIG.SYS is executed, the following screen message appears:

Stingray

Stingray Rev 3/4, VGA DOS Device Driver, Version 2.20

Copyright (c) Cirrus Logic Inc., 1988-1989. All Rights

Reserved. Keeping 15120 bytes of RAM.

5

## EAGLE.EXE

This setup utility program allows you to configure your LCD screen. EAGLE.EXE does the following:

- changes the video display to reverse or normal
- enables or disables the video expanded mode
- aligns the screen to the top, bottom, or center
- aligns the 720 dot fixup to left, right, or skip
- enables or disables the auto mapping feature
- changes the font display to bold or normal

LCD.COM - changes the video display to LCD and turns on the LCD panel

CRT.COM - changes the video display to CRT and turns off the LCD panel

### P41\_C000.SYS Utility

The video system has P41-C000.SYS program installed in the fixed disk. This program installs the video DOS device function of the system for updating video system performance.

To install this utility, add the following commands in your CONFIG.SYS file:

```
Device = C:\ P41_C000.SYS
```

## Running the EAGLE Utility

The EAGLE.EXE file when loaded automatically sets the values for the display environment.

1. To execute the program, type:

EAGLE

The following screen is displayed when in LCD VGA mode:

EAGLE, VGA Controller Utility Version 4.00 P5. VGA Video BIOS Version 2.20. Copyright (c) Cirrus Logic Inc., 1987-1989. All Rights Reserved.	
Current Selections	Alternate Selections
VGA Locked	Select CGA State
	Select MGA State
	Select EGA State
	Select Auto Switch State
Color	Select MONO mode
Normal	Enable FAST mode
Panel	Switch the display to the CRT
Expanded	Disable EXPAND mode
Reversed	Disable REVERSE VIDEO
Bold	Disable BOLD mode
Automap	Enable ATTRIBUTE EMULATION
Centered	Display unexpanded modes from top
	Display unexpanded modes from bottom
Left	Skip every 9th pixel
	Display MGA modes from RIGHT
	Or 8th and 9th pixel
Allow16	Force 8 bit operation
	Exit to DOS

5





The message below appears following the screen shown above:

EAGLE, VGA Controller Utility Version 4.00 P5.  
Copyright (c) Cirrus Logic Inc., 1987-1989. All Rights Reserved.

Stingray Rev 3/4, VGA BIOS Version 2.20 Preliminary 41  
Copyright (c) Cirrus Logic Inc., 1989. All Rights Reserved.

Cold boot state will be VGA Locked.  
Warm boot state will be VGA Locked.  
The VGA is currently in a color (3Dx) mode.

Display type is set to flat panel.  
Expanded mode is enabled.  
RAM is set to allow 16 bit. The VGA is running as a 16 bit device.  
Reverse video is set to enable reverse video.  
Attribute emulation is set to AUTOMAP.  
Bold font is enabled.  
Fast mode is set to safe.  
Centering is set to center unexpanded modes.  
MGA reduction is set to display MGA modes at left.

5

2. For LCD EGA mode, the following screen appears:

EAGLE, VGA Controller Utility Version 4.00 P5. VGA Video BIOS Version 2.20. Copyright (c) Cirrus Logic Inc., 1987-1989. All Rights Reserved.	
Current Selections	Alternate Selections
EGA Locked	Select VGA State
	Select CGA State
	Select MGA State
	Select Auto Switch State
Color	Select MONO mode
Normal	Enable FAST mode
Panel	Switch the display to the CRT
Normal	Enable EXPAND mode
Reversed	Disable REVERSE VIDEO
Bold	Disable BOLD mode
Automap	Enable ATTRIBUTE EMULATION
Centered	Display unexpanded modes from top
	Display unexpanded modes from bottom
Left	Skip every 9th pixel
	Display MGA modes from RIGHT
	Or 8th and 9th pixel
Allow16	Force 8 bit operation
	Exit to DOS



EAGLE, VGA Controller Utility Version 4.00 P5. Copyright (c)  
Cirrus Logic Inc., 1987-1989. All Rights Reserved.

Stingray Rev 3/4, VGA BIOS Version 2.20 Preliminary 41  
Copyright (c) Cirrus Logic Inc., 1989. All Rights Reserved.

Cold boot state will be VGA Locked.  
Warm boot state will be EGA locked.  
The VGA is currently in a color (3Dx) mode.

Display type is set to flat panel.  
Expanded mode is disabled.  
RAM access is set to allow 16 bit. The VGA is running as a 16  
bit device.  
Reverse video is set to enable reverse video.  
Attribute emulation is set to AUTOMAP.  
Bold font is enabled.  
Fast mode is set to safe.  
Centering is set to center unexpanded modes.  
MGA reduction is set to display MGA modes at left.



3. For LCD CGA mode, the following screen appears:

EAGLE, VGA Controller Utility Version 4.00 P5. VGA Video BIOS Version 2.20. Copyright (c) Cirrus Logic Inc., 1987-1989. All Rights Reserved.	
Current Selections	Alternate-Selections
CGA Locked	Select VGA State
	Select MGA State
	Select EGA State
	Select Auto Switch State
Color	Select MONO mode
Normal	Enable FAST mode
Panel	Switch the display to the CRT
Reversed	Disable REVERSE VIDEO
Bold	Disable BOLD mode
Automap	Enable ATTRIBUTE EMULATION
Centered	Display unexpanded modes from top
	Display unexpanded modes from bottom
Left	Skip every 9th pixel
	Display MGA modes from RIGHT
	Or 8th and 9th pixel
Allow16	Force 8 bit operation
	Exit to DOS



EAGLE, VGA Controller Utility Version 4.00 P5. Copyright (c)  
Cirrus Logic Inc., 1987-1989. All Rights Reserved.

Stingray Rev 3/4, VGA BIOS Version 2.20 Preliminary 41  
Copyright (c) Cirrus Logic Inc., 1989. All Rights Reserved.

Cold boot state will be VGA Locked.  
Warm boot state will be CGA locked.  
The VGA is currently in a color (3Dx) mode.

Display type is set to flat panel.  
Expanded mode is disabled.  
RAM access is set to allow 16 bit. The VGA is running as a 16  
bit device.  
Reverse video is set to enable reverse video.  
Attribute emulation is set to AUTOMAP.  
Bold font is enabled.  
Fast mode is set to safe.  
Centering is set to center unexpanded modes.  
MGA reduction is set to display MGA modes at left.



4. For LCD MGA mode, the following screen appears:

EAGLE, VGA Controller Utility Version 4.00 P5. VGA Video BIOS Version 2.20. Copyright (c) Cirrus Logic Inc., 1987-1989. All Rights Reserved.	
Current Selections	Alternate Selections
MGA Locked	Select VGA State
	Select CGA State
	Select EGA State
	Select Auto Switch State
	Select COLOR mode
Mono	Enable FAST mode
Normal	Switch the display to the CRT
Panel	Enable EXPAND mode
Normal	Disable REVERSE VIDEO
Reversed	Disable BOLD mode
Bold	Enable ATTRIBUTE EMULATION
Automap	Display unexpanded modes from top
Centered	Display unexpanded modes from bottom
	Skip every 9th pixel
Left	Display MGA modes from RIGHT
	Or 8th and 9th pixel
Allow16	Force 8 bit operation
	Exit to DOS

EAGLE, VGA Controller Utility Version 4.00 P5. Copyright (c)  
Cirrus Logic Inc., 1987-1989. All Rights Reserved.

Stingray Rev 3/4, VGA BIOS Version 2.20 Preliminary 41  
Copyright (c) Cirrus Logic Inc., 1989. All Rights Reserved.

Cold boot state will be VGA Locked.  
Warm boot state will be MGA locked.  
The VGA is currently in a MONO (3Bx) mode.

Display type is set to flat panel.  
Expanded mode is disabled.  
RAM access is set to allow 16 bit. The VGA is running as a 16  
bit device.  
Reverse video is set to enable reverse video.  
Attribute emulation is set to AUTOMAP.  
Bold font is enabled.  
Fast mode is set to safe.  
Centering is set to center unexpanded modes.  
MGA reduction is set to display MGA modes at left.

5

5. For CRT VGA mode, the following screen appears:

EAGLE, VGA Controller Utility Version 4.00 P5. VGA Video BIOS Version 2.20. Copyright (c) Cirrus Logic Inc., 1987-1989. All Rights Reserved.	
Current Selections	Alternate Selections
VGA Locked	Select CGA State
	Select MGA State
	Select EGA State
	Select Auto Switch State
Color	Select MONO mode
Normal	Enable FAST mode
CRT	Switch the display to the PANEL
Allow16	Force 8 bit operation
	Exit to DOS

EAGLE, VGA Controller Utility Version 4.00 P5. Copyright (c) Cirrus Logic Inc., 1987-1989. All Rights Reserved.

Stingray Rev 3/4, VGA BIOS Version 2.20 Preliminary 41 Copyright (c) Cirrus Logic Inc., 1989. All Rights Reserved.

Cold boot state will be VGA Locked.  
Warm boot state will be VGA locked.  
The VGA is currently in a color (3Dx) mode.

Display type is set to CRT monitor.  
RAM access is set to allow 16 bit. The VGA is running as a 16 bit device.  
Reverse video is set to disable reverse video.  
Fast mode is set to safe.





6. When display type is set to CRT EGA mode, the following screen appears:

EAGLE, VGA Controller Utility Version 4.00 P5. VGA Video BIOS Version 2.20. Copyright (c) Cirrus Logic Inc., 1987-1989. All Rights Reserved.	
Current Selections	Alternate Selections
EGA Locked	Select VGA State
	Select CGA State
	Select MGA State
	Select Auto Switch State
Color	Select MONO mode
Normal	Enable FAST mode
CRT	Switch the display to the Panel
Allow16	Force 8 bit operation
	Exit to DOS

EAGLE, VGA Controller Utility Version 4.00 P5. Copyright (c) Cirrus Logic Inc., 1987-1989. All Rights Reserved.



Stingray Rev 3/4, VGA BIOS Version 2.20 Preliminary 41 Copyright (c) Cirrus Logic Inc., 1989. All Rights Reserved.

Cold boot state will be VGA Locked.  
Warm boot state will be EGA Locked.  
The VGA is currently in a color (3Dx) mode.

Display type is set to CRT monitor.  
RAM access is set to allow 16 bit. The VGA is running as 16 bit device.  
Reverse video is set to enable reverse video.  
Fast mode is set to safe.

7. For CRT MGA mode, the following screen appears:

EAGLE, VGA Controller Utility Version 4.00 P5. VGA Video BIOS Version 2.20 Copyright (c) Cirrus Logic Inc., 1987-1989. All Rights Reserved.	
Current Selections	Alternate Selections
MGA Locked	Select VGA State
	Select CGA State
	Select EGA State
	Select Auto Switch State
Mono	Select COLOR mode
Normal	Enable FAST mode
CRT	Switch the display to the PANEL
Allow16	Force 8 bit operation
	Exit to DOS

EAGLE, VGA Controller Utility Version 4.00 P5.  
Copyright(c)Cirrus Logic Inc., 1987-1989. All Rights Reserved.

Stingray Rev 3/4, VGA BIOS Version 2.20 Preliminary 41  
Copyright (c) Cirrus Logic Inc., 1989. All Rights Reserved.

Cold boot state will be VGA Locked.

Warm boot state will be MGA locked.

The VGA is currently in a MONO (3Bx) mode.

Display type is set to CRT panel.

RAM access is set to allow 16 bit. The VGA is running as a 16  
bit device.

Reverse video is set to enable reverse video.

Fast Mode is set to safe.

8. For CRT CGA mode, the following screen appears:

EAGLE, VGA Controller Utility Version 4.00 P5. VGA Video BIOS Version 2.20 Copyright (c) Cirrus Logic Inc., 1987-1989. All Rights Reserved.	
Current Selections	Alternate Selections
CGA Locked	Select VGA State
	Select MGA State
	Select EGA State
	Select Auto Switch State
Color	Select MONO mode
Normal	Enable FAST mode
CRT	Switch the display to the PANEL
Allow16	Force 8 bit operation
	Exit to DOS

EAGLE, VGA Controller Utility Version 4.00 P5. Copyright (c)  
Cirrus Logic Inc., 1987-1989. All Rights Reserved.



Stingray Rev 3/4, VGA BIOS Version 2.20 Preliminary 41  
Copyright (c) Cirrus Logic Inc., 1989. All Rights Reserved.

Cold boot state will be VGA Locked.  
Warm boot state will be CGA locked.  
The VGA is currently in a COLOR (3Dx) mode.  
Display type is set to CRT monitor.  
RAM access is set to allow 16 bit.  
The VGA is running as a 16 bit device.  
Reverse video is set to enable reverse video.  
Fast mode is set to safe.

NOTES:

The LT3600 comes with a utility diskette. Some of the utilities are EAGLE, CRT and LCD.COM. EAGLE.COM has several options when invoked. Some of the options have bugs like PANEL and ALLOW16. When you want to change the display from internal to external, use CRT.COM in switching to external monitor and LCD.COM in switching back to internal monitor. This applies only in the PANEL option and not ALLOW16 which we haven't had any apparent solution for its bug.

*NOTE : If an external monitor is connected, turn off the LCD display immediately after warm booting then run CRT.COM to cut the LCD power. Follow these steps otherwise damages may be made in the LCD display.*



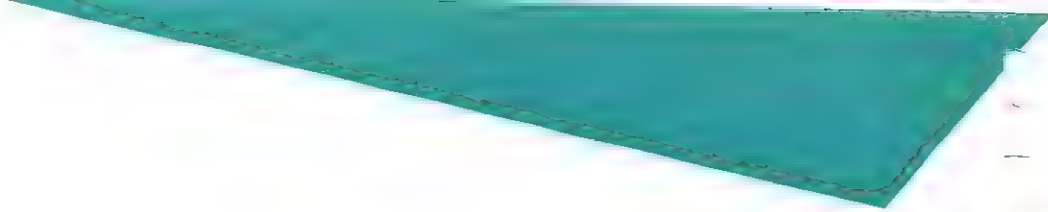

1  
2  
3  
4  
5  
6  
7  
8  
9  
10  
11  
12  
13  
14  
15  
16  
17  
18  
19  
20  
21  
22  
23  
24  
25  
26  
27  
28  
29  
30  
31  
32  
33  
34  
35  
36  
37  
38  
39  
40  
41  
42  
43  
44  
45  
46  
47  
48  
49  
50  
51  
52  
53  
54  
55  
56  
57  
58  
59  
60  
61  
62  
63  
64  
65  
66  
67  
68  
69  
70  
71  
72  
73  
74  
75  
76  
77  
78  
79  
80  
81  
82  
83  
84  
85  
86  
87  
88  
89  
90  
91  
92  
93  
94  
95  
96  
97  
98  
99  
100

\_\_\_\_\_

Chapter 6  
PROBLEM  
SOLVING

Archived by:

[www.  
retrospace.  
net](http://www.retrospace.net)

## Problem Solving

This chapter explains how to troubleshoot the system.

### Power-On Self Test (POST)

The system performs power-on self test (POST) every time you boot the system and the SETUP program can be accessed using the DEL key. The POST is a series of system checks and initialization that verifies the correct operation of the base system. Two classifications of malfunctions that may be detected during the POST: critical (fatal) and non-critical.

Critical malfunctions prevent the system from operating at all or could cause incorrect results that are apparent to the user. Examples of critical errors include processor or interrupt controller malfunctions.

Non-critical malfunctions are those that cause incorrect results which may not be apparent to the user. An example of a non-critical error would be a memory chip failure.

If a critical error is detected during the POST, an attempt is made to indicate the error and all testing will halt. On a non-critical error, an error code is displayed and testing is stopped. Testing can be continued on a non-critical error, by pressing the F1 key.







After a successful POST, where no critical errors were detected, the system prompt will be shown. Control is then given to the system boot strap loader.

It is important to remember that the POST does not test all areas, but only those that allow the system to be operational enough to run any diagnostic program.

## Identifying and Solving System Problems

It is inevitable that you may encounter problems with your computer. Problems with your computer are caused by hardware, software, or both.

Effective troubleshooting requires that you (1) make a written list of the symptoms, and (2) localize the problem. Some computer problems may require the technical assistance of your dealer. Before calling for service, check for possible solutions in this section.



### Problems at Initial System Startup

If you are having startup problems, make certain that the system connects to a properly grounded electrical outlet and all other peripheral devices connects to the system. Each time you turn-on the system, firmware runs a system power-on self-test to verify correct functioning of system components and to determine if the system is properly configured. If the system detects a problem, it displays an error message on the screen, usually accompanied by a pattern of long and/or short beeps.

In such cases, proceed as follows:

1. Record any error messages and the beep pattern.
2. Refer to the following discussion for corrective action.
3. Restart the system.
4. If the same error message(s) and beep pattern occur, contact your authorized dealer.

### System Startup Problems

1. System does not beep when turned on. Listen to determine if the fan is running. If the fan is not operating, check that the power cord connects to a live power outlet and to the system. If your system does not work when plugged into a known working power outlet, take your system to your dealer or an authorized service center to have its own power supply checked.
2. System beeps, but no cursor appears on your monitor. Be sure the brightness and contrast controls are adjusted properly. If this is the first time this system configuration is being booted, make sure you are using the correct switch setting for the video adapter type. They should match your built-in VGA.
3. System displays MEM ERROR or PARITY CHECK. Take your system to your dealer or an authorized service center to have its RAM chips checked if memory problems are indicated.
4. System beeps, the cursor blinks on the monitor, but the FDD light does not go on. If your flexible controller cable is in place, take your system to your dealer or an authorized service center to have its fixed disk controller card and flexible disk drive checked.

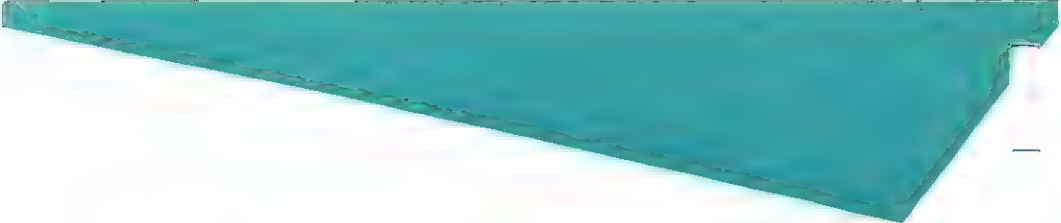
- 
5. System beeps twice (or more), and monitor screen is blank.  
Send the system unit for repair.
  6. System beeps, the FDD light goes on, but one of the following error messages appear:

**Disk Error**                      This message indicates that no boot sector can be read, because either no disk was inserted in the drive, the disk was not readable, or the disk drive lever had not been turned down.

**Disk Boot Failure**              This message is displayed when one or both of the MS-DOS hidden system files is missing from the diskette.

**Bad or Missing  
Command Interpreter**          This error message represents a corrupt or missing COMMAND.COM on the diskette. In either case, the boot may be attempted again by pressing <Enter>. Repeat the boot operation with another copy of the system diskette. If the failure persists, take your system to your dealer or an authorized service center.





## Problems With a Fixed Disk Drive

1. System will no longer boot from the fixed disk drive even though the drive light goes on.
  - Boot your system from the flexible drive within an MS-DOS disk. Then try to read the directory on the fixed disk by typing DIR C:. If you can read the fixed disk directory, reinstall the system onto drive C by typing SYS C:, then press <Enter>.
  - If this does not make the system bootable, back up any files that are not already backed up, and reinstall MS-DOS on your fixed disk through the use of FORMAT and COPY. Detailed instructions for installing MS-DOS on your fixed disk can be found in your MS-DOS Manual. RESTORE your files to the fixed disk from your most recent backup.
2. System does not boot from the fixed disk, and you cannot read a directory or files from it when booting from the flexible disk.
  - Unplug the system and remove its cover. Boot your system from flexible drive A.
  - Reinstall MS-DOS on your fixed disk through the use of FORMAT and COPY. RESTORE your files to the fixed disk from the most recent backup.
  - If your fixed disk cannot be formatted, take your system to your dealer or an authorized service center to have the fixed-disk drive checked.





## Problems With a Diskette Drive

1. Diskette drive in-use light stays on. If there is a diskette in the drive, check to see that:
  - The diskette is not damaged. Try a backup copy if you have one.
  - The diskette is inserted correctly – label up and metal-shutter end first.
  - Your software program is OK.

If the problem persists, have the system unit serviced.

2. Drive doesn't respond to boot command (diskette drive in-use light doesn't come on). Check to see that:
  - Disk drive cable is securely plugged in.
  - Disk drive cable is not defective (with one or more broken conductors). If defective, replace cable.
  - Power supply cable is securely connected in the power case on the diskette drive.



If none of the above items is the cause, the FDC board and/or diskette drive logic board may be defective. Replace board if possible, or send it for repair.

3. Diskette drive in-use light turns on when boot command is given but disk will not boot. Check the format version of your diskette and clean the disk drive head. If there are any loose parts in the drive, send it for repair.

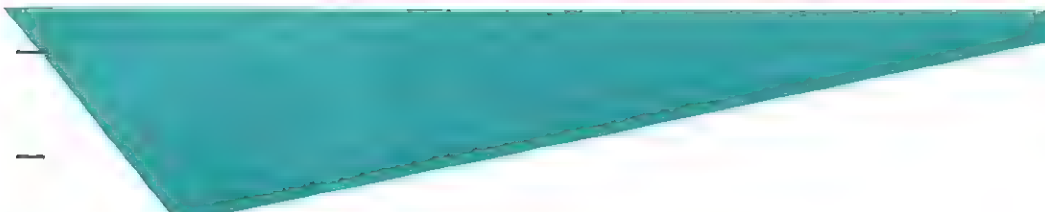
- 
4. **Problems inserting or removing diskettes.** These may be due to:
- Head not released from read/write (loaded) position. Close the disk drive with the disk drive latch and release once more. If this does not work, turn off the system, then on. Try to insert a scratch disk. If the problem remains, read on to the next cause.
  - Springs or catches bent or broken. Turn off the system. Open disk drive, remove the logic board, and use a scratch disk to isolate the problem. Send drive for repair if necessary.
  - Drive hub gummed up with adhesive from hub rings. Carefully clean with lint-free cloth moistened with lighter fluid.
  - Write-protect or other label stuck somewhere in disk pathway. Remove and clean off adhesive.



## Problems When Running a New Application Program

1. Application program is not running correctly. Your computer must have the minimum memory space requirements to use the software. Refer to the software manuals for verification. If necessary, delete unnecessary files to accommodate the software requirements. Reinstall the application program.
2. System halts or an NMI error occurs. A hardware-software incompatibility may cause the system to stop execution. This condition occurs when:
  - The serial and parallel port on the system board uses the same address as the serial/parallel port of the adapter card. Change the serial/parallel port address of the adapter card.
  - You installed the wrong type of printer to your application program. Reinstall the application program with the correct printer.

If these solutions do not work, the software may have been designed for a different type of computer.



The system may halt when there is a component (memory IC) defect. Turn off the system, then turn on again after a few seconds. Execute the diagnostics program to check the cause. If the problem persists, contact your dealer.

An NMI error may be due to memory parity errors or to an I/O expansion board error. Replace the I/O expansion board.



## **Problems After the System and Software are Running Correctly**

1. If you received any error messages when using the software program, refer to the manuals supplied with the software for a description of the messages and solutions to the problem.
2. The screen shows random "garbage" (meaningless jumble of characters). The diskette has some damaged sectors, the file is damaged, or the file is not a readable text file.
3. Other intermittent problems. When a problem is difficult to find because it occurs occasionally, check the following:
  - All cables and cords are tightly connected to the rear of the system unit and attached options.

## **Problems With Peripheral Devices and Other Optional Components**

1. All or some keys on the keyboard do not work. If the testing programs on the diagnostics program can not find the problem, have the keyboard serviced.
2. The mouse or pointing device does not work. Check the instructions supplied with the mouse or pointing device for additional testing information. If no testing information is available, have the mouse or pointing device serviced.

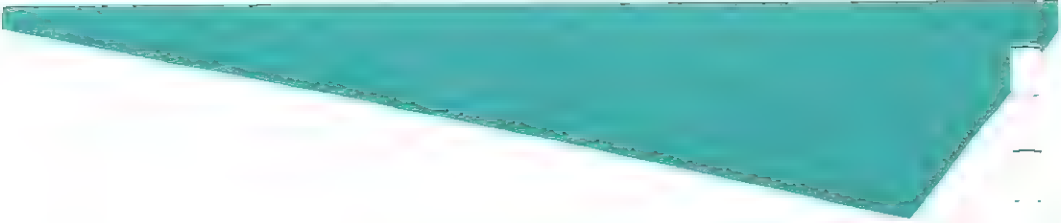

- 
3. **External 5.25-inch flexible-disk drive does not work.**
    - If all the settings are correct and the cables are properly connected, and the problem still occurs, consult your dealer.
  4. **The printer does not work.**
    - Check that the printer is turned on and is "online".
    - Check that the printer signal cable is properly connected to the system unit.



## Power-On Self-Test Error Codes

The following are some of the error messages that you may encounter during the power-on self-test (POST).

<b>Error Message</b>	<b>Probable Cause</b>	<b>Recommended Action</b>
Memory error	Memory failure	Contact dealer
System Memory address error	Memory failure	Contact dealer
Keyboard error	Keyboard failure	Run Setup
Diskette drive controller error	System board	Contact dealer
Diskette drive error	Mismatch in drive type	Run Setup program
Fixed disk C error	Fixed disk drive C error	Contact dealer

<b>Error Message</b>	<b>Probable Cause</b>	<b>Recommended Action</b>
Parallel port error	Wrong setup or connection	Contact dealer
Serial port error wrong setup	Added or removed async board/	Contact dealer
RAM parity error	Parity error	Contact dealer
Equipment configuration error	Wrong configuration	Run Setup program
Memory size mismatch	Configuration memory incorrect	Run Setup program

<b>Error Message</b>	<b>Probable Cause</b>	<b>Recommended Action</b>
Disk C extended type error	Mismatch in drive type	Run Setup program
Fixed disk controller error	System board	Contact dealer
Keyboard interface error	Keyboard or system board	Contact dealer
Press F1 key	Any failure	Press F1 key, and follow the instructions on the screen

## Troubleshooting

### Does your system boot and display the boot message?

Check the following:

- AC power cord plugged into the receptacle and the system unit.
- System's power switch is in the ON position.
- Check the CMOS Setup program. Check the fixed-disk drive type in the Setup program.
- Fixed-disk drive is formatted and contains the MS-DOS operating system files.
- Presence of a non-system disk on the diskette-drive.
- Check if the battery is empty thru the LED display.
- Power off and on the system and press Ins key. If the screen has no display and a possible boot failure has occurred, contact your dealer.





### **Is there a flexible-disk drive failure?**

Check the following:

- Flexible-disk drive is correctly configured in the SETUP.
- Check the connection of the power cable and flexible-disk drive flat cable. Replace the flexible-disk drive when it does not work after checking that all cables are connected properly.
- The system rebooted without any problems. Flexible-disk drive works with a system diskette. Contact your dealer.

### **Is there a keyboard failure?**

Check the following:

- Keyboard cable has good mating with the motherboard.
- All of the keyboard keys are working properly.
- Keyboard responds and prints the right character.
- Check the keyboard controller chip. If the problem is not in the keyboard controller chip or keys, send the keyboard to the service center.







## Other Troubleshooting Tips

### Using a LED connected to port 80h

When the BIOS goes through the Power-On Self-Test, it outputs a series of values at different points in the BIOS to port 80h to indicate the test it has passed. These are called check points. In case of an error when the system locks up, the display will show the area where the problem exists. The following is a sequential list of the check points and the meanings associated with them.



### List of Check Points

Check Point	Meaning
01	NMI disabled and 80286 register test about to start
02	80286 register test over
03	ROM checksum OK
04	8259 initialization OK
05	CMOS pending interrupt disabled
06	Video disabled and system timer counting OK
07	CH-2 or 8253 test OK
08	CH-2 of delta count test OK
09	CH-1 delta count test OK
0A	CH-0 delta count test OK
0B	Parity status cleared
0C	Refresh and system timer OK
0D	Refresh link toggling OK
0E	Refresh periods ON/OFF 50% OK
10	Confirmed refresh ON & about to start 64 K memory
11	Address line test OK
12	64 K base memory test OK



<b>Check Point</b>	<b>Meaning</b>
13	Interrupt vectors initialized
14	8042 keyboard controller test OK
15	CMOS read/write test OK
16	CMOS checksum/battery check OK
17	Monochrome mode set OK
18	Color mode set OK
19	About to look for optional video ROM
1A	Optional video ROM control OK
1B	Display memory R/W test OK
1C	Display memory R/W test for alternate display OK
1D	Video retrace check OK
1E	Global equipment byte set for video OK
1F	Mode set call for Mono/Color OK
20	Video set OK
21	Video display OK
22	Power on message display OK
30	Virtual mode memory test about to begin
31	Virtual mode memory test started
32	Processor in virtual mode
33	Memory address line test in progress
34	Memory address line test in progress
35	Memory below 1 MB calculated
36	Memory size computation OK

<b>Check Point</b>	<b>Meaning</b>
37	Memory test in progress
38	Memory initialization below 1 MB
39	Memory initialization above 1 MB
3A	Display memory size
3B	About to start below 1 MB memory test
3C	Memory test below 1 MB OK
3D	Memory test above 1 MB OK
3E	About to go to real mode (shutdown)
3F	Shutdown successful and entered in real mode
40	About to disable gate A-20 address line
41	Gate A-20 line disabled successfully
42	About to start DMA controller test
4E	Address line test OK
4F	Processor in real mode after shutdown
50	DMA page register test OK
51	DMA unit-1 base register test about to start
52	DMA unit-1 channel OK, about to begin CH-2
53	DMA CH-2 base register test OK
54	About to test F/F latch for unit-1
55	F/F latch test both unit OK
56	DMA unit 1 & 2 programmed OK
57	8259 initialized over
58	8259 mask register check OK
59	Master 8259 mask register OK, about to start slave

Check Point	Meaning
5A	About to check timer and keyboard inter.level
5B	Timer interrupt OK
5C	About to test keyboard interrupt
5D	ERROR timer/keyboard inter. not in proper level
5E	8259 interrupt controller error
5F	8259 interrupt controller test OK
70	Start of keyboard test
71	Keyboard BAT test OK
72	Keyboard test OK
74	Floppy setup about to start
75	Floppy setup OK
76	Hard disk setup about to start
77	Hard disk setup OK
79	About to initialize timer data area
7A	Verify CMOS battery power
7B	CMOS battery verification done
7D	About to analyze diagnostics test results for memory
7E	CMOS memory size update OK
7F	About to check optional ROM C0000
80	Keyboard sensed to enable SETUP
81	Optional ROM control OK
82	Printer global data initialization OK
83	RS-232 global data initialization OK
84	80287 check/test OK
85	About to display soft error message
86	About to give control to system ROM E0000
87	System ROM E0000 check over
00	Control given to INT19, boot loader

## **Error Messages**

The following errors are considered as fatal errors:

- Channel -2 of timer not functional.
- Stray interrupt sensed in controller.
- Interrupt controller #2 not functional.

The following errors are considered as non-fatal errors:

- Keyboard error.
- Keyboard/interface error.
- CMOS battery state low.
- CMOS system options not set.
- CMOS checksum failure.
- CMOS memory size mismatch.
- CMOS system time and date not set.
- CMOS display configuration mismatch.
- Display setting not proper.
- Keyboard is locked...Unlock it.
- Floppy disk controller failure.
- Hard disk unit 0 error.
- Hard disk unit 1 error.
- Hard disk unit 0 failure.
- Hard disk unit 1 failure.

- Hard disk unit 1 is not defined in CMOS.
- Cache memory bad - Do not enable cache.

The following errors through beeps are considered as non-fatal errors:

- Beep count 3 - conventional and extended test failure
- Beep count 8 - display test and display vertical and horizontal retrace test failed

The following are fatal errors through the display:

- CMOS Inoperational - indicates failure of CMOS shutdown register set.
- 8042 Gate-A20 Error - indicates error in getting into protected mode
- DMA Error - indicates failure in DMA controller page register set
- DMA #1 Error - indicates failure in in DMA unit #1
- DMA #2 Error - indicates failure in in DMA unit #2



The following are fatal errors through the display:

- Press F1 key - there is a need to run SETUP
- Press F1 key - there is no need to run SETUP

## Errors Reported by the System

The system performs various diagnostic tests at the time the system is powered up. Whenever an error is encountered during these tests either you hear a few short beeps or see an error display on your monitor. If the error occurs before the display device is initialized, the system reports the error by giving a number of short beeps.

If the error is fatal the system halts after reporting the fatal error. If the error is non-fatal, the process continues after reporting the non-fatal error.

### Fatal Errors

The table below lists the fatal errors:

Table 4-1. Fatal Errors

Beep Count	Meaning
1	DRAM refresh failure.
3	Base 64 KB RAM failure.
4	System timer failure.
5	Processor failure.
6	Keyboard controller - Gate A20 error.
7	Virtual mode exception error.
9	ROM-BIOS checksum failure.



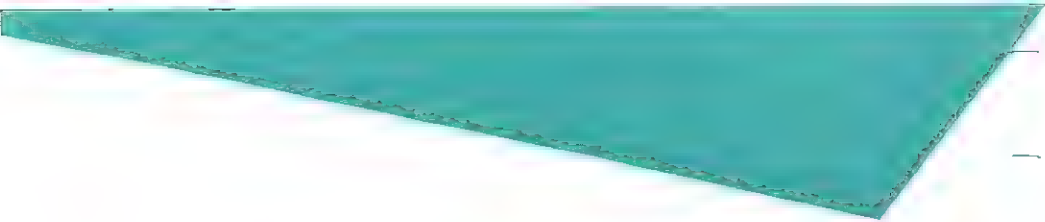

**Notes:**



Chapter 7  
CARING  
FOR  
THE  
SYSTEM

1  
2  
3  
4  
5  
6  
7  
8  
9  
10  
11  
12  
13  
14  
15  
16  
17  
18  
19  
20  
21  
22  
23  
24  
25  
26  
27  
28  
29  
30  
31  
32  
33  
34  
35  
36  
37  
38  
39  
40  
41  
42  
43  
44  
45  
46  
47  
48  
49  
50  
51  
52  
53  
54  
55  
56  
57  
58  
59  
60  
61  
62  
63  
64  
65  
66  
67  
68  
69  
70  
71  
72  
73  
74  
75  
76  
77  
78  
79  
80  
81  
82  
83  
84  
85  
86  
87  
88  
89  
90  
91  
92  
93  
94  
95  
96  
97  
98  
99  
100



## Caring for Your System

This chapter tells you how to take care of the system unit.

### Maintenance

The system actually requires little care. Observe the following guidelines to maintain the computer's condition and performance:

- Periodically wipe the exterior with a soft, damp cloth to keep the case looking like new.
  - When necessary clean the display by spraying window cleaner on a soft cloth and then wiping the display. Never apply a cleaner directly to the display.
  - Keep the computer away from excessive moisture and extremes of temperatures. Never expose the system unit or the AC adapter to liquids or precipitation. See Appendix A for detailed system specifications.
  - To avoid damage to the display, do not place anything on the top of the computer when it is closed.
  - Keep liquids away from the computer.
- 



## Moving the System

Improper preparation of the system before moving can cause damage to data on the fixed disk or damage to parts of the system itself. The basic steps to perform before moving include backing up the files from the fixed disk, protecting the flexible drive head, and repacking the components.

To move the system safely, take these simple precautions to avoid damage to your system or loss of data:

1. Back up all files stored on fixed-disk drives.
2. Turn off the power switch and disconnect the power cord.
3. Disconnect the 5.25-inch disk drive if it is connected to the system.

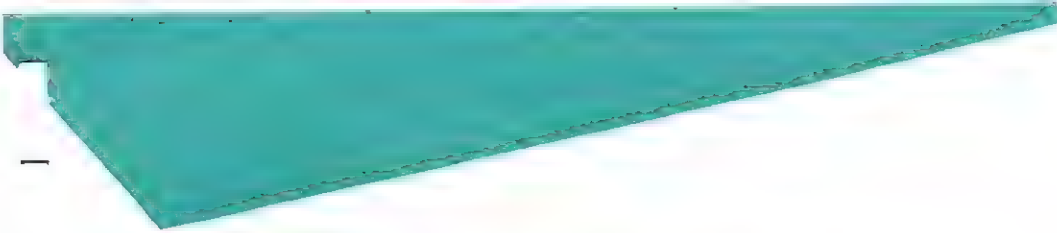

- 
4. Disconnect any other external peripherals such as printers and modems.
  5. Insert drive protection cards in the flexible-disk drives. If you do not have a drive protection card, use a blank flexible disk.
  6. Close and latch the display.
  7. Disconnect the AC adapter from the computer, and take along either the AC adapter or an extra battery pack that has been charged.
  8. Pack the system components as described in the next section.
  9. Whenever you travel with the computer, hand-carry the computer. Do not check the computer as luggage.



## Packing the System

You need not pack the system components if the system is to be moved only for a short distance, as from one room to another in the same building. In moving the system for a short distance, use the system's handle on the front side (near the display latch).

When the system has to be moved by vehicle, pack the system and other components in the carrying bag to avoid damage.



Appendix A  
SYSTEM  
SPECIFICATIONS





## Specifications

	<b>Standard</b>
CPU	80C286-16
System Speed	10 MHz (normal) 20 MHz (turbo speed)
Coprocessor Option:	Socket Intel 80287 (10/12 MHz)
On-Board RAM Expandable	1 MB to 5 MB
On-Board ROMs	128 KB (27512 x 2) or 64 KB (27256 x 2)
Video ROM	64 KB (for VGA BIOS)
Video	Built-in VGA board
Video RAM Controller	256 KB

Expansion Slot	One 16-bit PC AT slot <b>Standard</b>	—
I/O Ports	2 serial ports 1 parallel port 1 flexible disk interface	—
Data Storage	3.5-inch/5.25-inch	—
Diskette Drive	5.25-inch (720 KB/1.2 MB x 1) 3.5-inch (1.44 MB x 1)	—
Fixed Disk Drive	3.5-inch (40 MB x 1; 28 ms access time)	—
Power Input	16.5 ± 0.2 Vdc	—
Keyboard	82-key   101 /102-keys embedded keyboard   external keyboard	—
Operating Temp.	10°C to 40°C	—
Storage Temp.	-20°C to 60°C	—
Operating Humidity	20% to 80%, non-condensing	—
Storage Humidity	5% to 80%, non-condensing	—

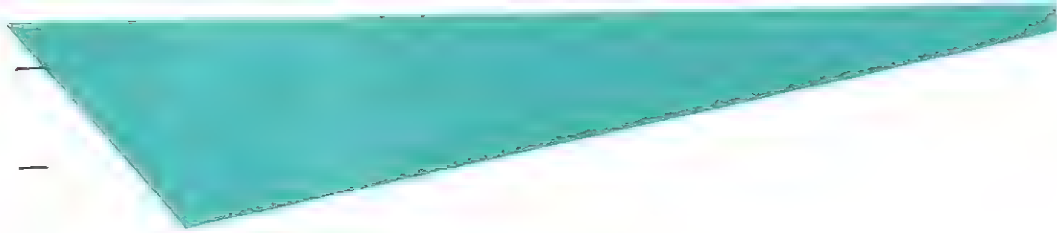

## Display Characteristics

Background color	Ivory white
Character size	7 by 7 dots
Characters per line:	80
Contrast:	Adjustable
Display cell size	8 by 8 dots
Display Format	W = 640 dot; H = 480 dot
Dot color	Black
Lines per screen:	25
Resolution	640 by 480, VGA compatible graphic mode with 16-gray scale
Technology	11-inch Liquid crystal display with CCFT backlight (LCD)
Viewing angle:	90°

## Power Requirements

### AC adapter input power:

Nominal voltage: 90~270 Vac  
Input frequency: 50/60 Hz, single-phase

### DC output power:

Nominal voltage: 16.5 Vdc  
Maximum current: 3.6 ampere

### Battery power (from battery pack):

Nominal voltage: 12 Vdc  
Nominal current: 1 to 2.2 ampere

## DC/DC Converter Module

Input dc 11.0 V ~ 18.0 V maximum 3.6 A

Output voltage and currents

Output Voltage	Typical Current	Max Load
+ 5 V	4.5 A	5 A
+ 12 V	1.0 A	1.4 A
- 5 V	0.1 A	0.2 A
+ 12 V	0.1 A	0.15 A
+ 32 V	0.4 A	0.4 A

## Hard Disk Controller

Number of disks	1
Capacity	40/100 MB (formatted)
Track Density	1150 tr/inch
Start time	5 sec (10 sec max)
Power supply	$12 \pm 5\% V_{dc}$
Power supply	$5 \pm 5\% V_{dc}$

## Flexible Disk Controller

Mode	High density read/write
Disk HD 3.5-inch	
Capacity	1.44 MB (unformatted)
Density	135 tpi
Power supply	5 V 12 V

## AC Adapter

Input voltage	90 V <sub>ac</sub> 270 V <sub>ac</sub>
Input leakage current	0.75 mA max

Input voltage	90 V <sub>ac</sub> 270 V <sub>ac</sub>
Input leakage current	0.75 mA max
Output voltage	+16.5 ± 0.2 Vdc
Output current	3.0 A max; 0 A min

### Battery Pack

Battery type	NiCad, 4400 mAh, 1.2 V x 10
Input voltage	16.5 V <sub>dc</sub> ± 0.2%
Nominal output voltage	12 V <sub>dc</sub>
Capacity	4.4 AH
Power	48 W
Charging current	1.1 A (nominal)
Charge hours	4~8 hrs



## VGA Modes of Operation

The following table describes the video modes supported by the Cirrus video controller.

Mode (hex)	Type <sup>1</sup>	CRT Color		
0, 1	A/N	4/256K	40 x 25	CGA text
2, 3	A/N	4/256K	80 x 25	CGA text
0 <sup>2</sup> , 1 <sup>2</sup>	A/N	16/256K	40 x 25	CGA text
2 <sup>2</sup> , 3 <sup>2</sup>	A/N	16/256K	80 x 25	EGA text
0 <sup>3</sup> , 1 <sup>3</sup>	A/N	16/256K	40 x 25	EGA text
2 <sup>3</sup> , 3 <sup>3</sup>	A/N	16/256K	80 x 25	VGA text
4, 5	APA	4/256K	320 x 200	VGA text
6	APA	2/256K	640 x 200	CGA gr
7	A/N	mono	80 x 25	CGA gr
				MGA text

<sup>1</sup> Text mode = A/N, and graphic mode = APA

<sup>2</sup> Enhanced modes from the IBM Enhanced Graphics Adapter (EGA)

<sup>3</sup> Enhanced modes

Mode (hex)	Type <sup>4</sup>	CRT		
		Color		
7 <sup>3</sup>	A/N	mono	80 x 25	VGA text
D	APA	16/256K	320 x 200	EGA gr
E	APA	16/256K	640 x 200	EGA gr
F <sup>2</sup>	APA	mono	640 x 350	EGA gr
10 <sup>2</sup>	APA	16/256K	640 x 350	EGA gr
11	APA	2/256K	640 x 480	VGA gr
12	APA	16/256K	640 x 480	VGA gr
13	APA	256/256K	320 x 200	VGA gr
HGC	APA	Mono	720 x 348	HGC gr

---

<sup>4</sup> Text mode = A/N, and graphic mode = APA

Mode (hex)	Color Emulation	No Expansion	Cell Display Area	Size
0, 1	Color attr. emul		640 x 400	16 x 16
2, 3	Color attr. emul		640 x 400	8 x 16
0 <sup>2</sup> , 1 <sup>2</sup>	Color attr. emul		640 x 350	16 x 14
2 <sup>2</sup> , 3 <sup>2</sup>	Color attr. emul		640 x 350	8 x 14
0 <sup>3</sup> , 1 <sup>3</sup>	Color attr. emul		640 x 400	16 x 16
2 <sup>3</sup> , 3 <sup>3</sup>	Color attr. emul		640 x 400	8 x 16
4, 5	4-gray scale/ACB		640 x 400	2 x 2
6	2-gray scale/ACB		640 x 400	1 x 2
7	Mono attr. emul		640 x 350	8 x 14
7 <sup>3</sup>	Mono attr. emul		640 x 400	8 x 16
DAPA	16-gray scale		640 x 400	2 x 2
EAPA	16-gray scale		640 x 400	1 x 2
F <sup>2</sup>	On/Off/blank/half		640 x 350	1 x 1
10 <sup>2</sup>	16-gray scale		640 x 350	1 x 1
11	2-gray scale/ACB		640 x 480	1 x 1
12	16-gray scale		640 x 480	1 x 1
13	32-gray scale		640 x 400	2 x 2
<b>Mono</b>	<b>Image comp/pan</b>		<b>640 x 350</b>	<b>1 x 1</b>

Mode (hex)	Color Emulation	W/ Expansion	Cell Display Area	Size
0, 1	Color attr. emul		640 x 475	16 x 19
2, 3	Color attr. emul		640 x 475	8 x 19
0 <sup>2</sup> , 1 <sup>2</sup>	Color attr. emul		640 x 475	16 x 19
2 <sup>2</sup> , 3 <sup>2</sup>	Color attr. emul		640 x 475	8 x 19
0 <sup>3</sup> , 1 <sup>3</sup>	Color attr. emul		640 x 475	16 x 19
2 <sup>3</sup> , 3 <sup>3</sup>	Color attr. emul		640 x 475	8 x 19
4, 5	4-gray scale/ACB		640 x 475	2 x 2
6	2-gray scale/ACB		640 x 475	1 x 2
7	Mono attr. emul		640 x 475	8 x 19
7 <sup>3</sup>	Mono attr. emul		640 x 475	8 x 19
D	APA 16-gray scale		640 x 475	2 x 2
E	APA 16-gray scale		640 x 475	1 x 2
F <sup>2</sup>	On/Off/blank/half		640 x 475	1 x 1
10 <sup>2</sup>	16-gray scale		640 x 475	1 x 1
11	2-gray scale/ACB		640 x 480	1 x 1
12	16-gray scale		640 x 480	1 x 1
13	32-gray scale		640 x 475	2 x 2
Mono	Image comp/pan		640 x 475	1 x 1

ACB stands for automatic contrast balancing and HGC for Hercules mode.

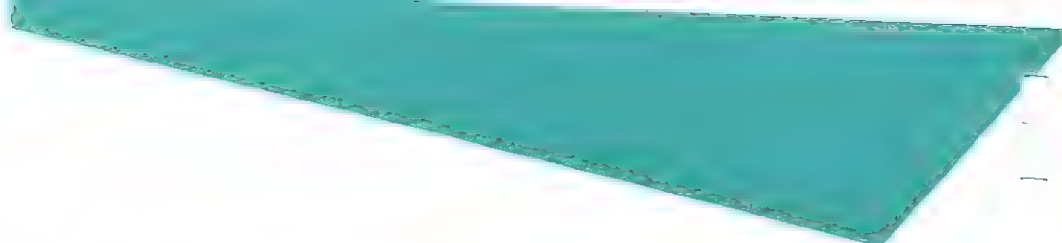

For **color attribute emulation**, when foreground and background colors are different, they are mapped to high contrast gray scale. When foreground and background colors are the same, then different gray scales are selected to enhance contrast.

For **monochrome attribute emulation**, straightforward mapping of monochrome attributes to gray scales similar to the CRT case.

**Appendix B**  
**I/O**  
**PORT**  
**CONNECTORS**



# I/O Port Connectors

## FDD Controller

Pin No	Signal Name	Pin No	Signal Name
1	GND	2	-RPM/RWC
3	GND	4	NC
5	GND	6	NC
7	GND	8	-INDEX
9	GND	10	-MT1ON
11	GND	12	DS0
13	GND	14	DS1
15	GND	16	-MT0ON
17	GND	18	-DIRC
19	GND	20	-STEP
21	GND	22	-WDD
23	GND	24	-WE
25	GND	26	-TR00
27	GND	28	-WP
29	GND	30	-RDD
31	GND	32	-SIDE 1
33	GND	34	-DCHNG



## HDD Connector

Pin No	Signal Name	Pin No	Signal Name
1	-HORST	2	GND
3	HD7	4	HD8
5	HD6	6	HD9
7	HD5	8	HD10
9	HD4	10	HD11
11	HD3	12	HD12
13	HD2	14	HD13
15	HD1	16	HD14
17	HD0	18	HD15
19	GND	20	NC
21	NC	22	GND
23	-HIOW	24	GND
25	-HIOR	26	GND
27	NC	28	HALE
29	NC	30	GND
31	HIRQ14	32	-IOCS16
33	HA1	34	GND
35	HA0	36	HA2
37	-HDD	38	-FDD
39	-HACT	40	GND

## COMM2 and COMM1

Pin No	Signal Name	I/O	Description
1	DCD	I	Data carrier detect
2	RD	I	Received data
3	SD	O	Transmitted data
4	DTR	O	Data terminal ready
5	GND		Signal ground
6	DSR	I	Data set ready
7	RTS	O	Request to send
8	CTS	I	Clear to send
9	RI	I	Ring indicator

## CRT Interface

Pin No	Signal Name
1	Red
2	Green
3	Blue
4	MS2
5	Gnd
6	Gnd
7	Gnd
8	Gnd
9	Gnd
10	NC
11	MS0
12	MS1
13	Hsync
14	Vsync

## 25-Pin External FDD

Pin No	Signal Name	I/O	Description
1	-RWC	I	Reduced write current
2	IDX	I	Index
3	-DS	O	Drive select
4	-MTON	O	Motor enable
5	-DIR	O	Direction
6	-STEP	O	Step pulse
7	-WD	O	Write data
8	-WE	O	Write enable
9	-TRK0	I	Track 0
10	-WP	I	Write protect
11	-RDD	I	Read data
12	-S1	O	Select head
13	-DCHG	O	Disk change
14~15			+5 V
16~		17	+12 V
18	-DS	I	Drive select
19~25		GND	I

## 25-Pin External Printer

Pin No	Signal Name	I/O	Description
1	-STROBE	O	Data strobe
2	D0	O	Data bit 0
3	D1	O	Data bit 0
4	D2	O	Data bit 0
5	D3	O	Data bit 0
6	D4	O	Data bit 0
7	D5	O	Data bit 0
8	D6	O	Data bit 0
9	D7	O	Data bit 0
10	-ACK	I	Acknowledge
11	BUSY	I	Busy
12	PE	I	P.End (out of paper)
13	SLCT	O	Select
14	-AUTOFD	O	Auto feed
15	-ERROR	I	Error
16	-INIT	O	Initialize printer
17	-SLCT IN	O	Select input
18~25	GND		Ground

## Expansion Slot (A & B)

Pin No.	A Signal	I/O	Pin No.	B Signal	I/O
A1	-I/O CHCK I		B1	GND	Ground
A2	SD7	I/O	B2	RESET DRV	O
A3	SD6	I/O	B3	+ 5 Vdc	Power
A4	SD5	I/O	B4	IRQ9	I
A5	SD4	I/O	B5	-5 Vdc	Power
A6	SD3	I/O	B6	DRQ2	I
A7	SD2	I/O	B7	-12 Vdc	Power
A8	SD1	I/O	B8	-0WS	I
A9	SD0	I/O	B9	+ 12 Vdc	Power
A10	I/O CHDRY I		B10	GND	Ground
A11	-AEN	O	B11	-SMEMW	O
A12	SA19	O	B12	-SEMER	O
A13	SA18	O	B13	-IOW	I/O
A14	SA17	O	B14	-IOR	I/O
A15	SA16	O	B15	-DACK3	O
A16	SA15	O	B16	DRQ3	I
A17	SA14	O	B17	-DACK1	O
A18	SA13	O	B18	DRQ1	I
A19	SA12	O	B19	-REFRESH	O
A20	SA11	O	B20	CLK	O
A21	SA10	O	B21	IRQ7	I
A22	SA9	O	B22	IRQ6	I
A23	SA8	O	B23	IRQ5	I
A24	SA7	O	B24	IRQ4	I
A25	SA6	O	B25	IRQ3	I
A26	SA5	O	B26	-DACK2	O
A27	SA4	O	B27	T/C	O
A28	SA3	O	B28	BALE	O
A29	SA2	O	B29	+ 5 Vdc	Power
A30	SA1	O	B30	OSC	O
A31	SA0	O	B31	GND	Ground

## Expansion Slot (C & D)

Pin No.	Side C		Side D		
	Signal Name	I/O	Pin No.	Signal Name	I/O
C1	SBHE	I/O	D1	-MEM CS16	I
C2	LA23	I/O	D2	-I/O CS16	I
C3	LA22	I/O	D3	IRQ10	I
C4	LA21	I/O	D4	IRQ10	I
C5	LA20	I/O	D5	IRQ10	I
C6	LA19	I/O	D6	IRQ10	I
C7	LA18	I/O	D7	IRQ10	I
C8	LA17	I/O	D8	-DACK0	O
C9	-MEMR	I/O	D9	DRQ0	I
C10	-MEMW	I/O	D10	-DACK5	O
C11	SD08	I/O	D11	DRQ5	I
C12	SD09	I/O	D12	-DACK6	O
C13	SD10	I/O	D13	DRQ6	I
C14	SD11	I/O	D14	-DACK7	O
C15	SD12	I/O	D15	DRQ7	I
C16	SD13	I/O	D16	+ 5 Vdc	Power
C17	SD14	I/O	D17	-MASTER	I
C18	SD15	I/O	D18	GND	Gnd

**Appendix C**  
**PROGRAMMING**  
**LVGAKEYB.COM**  
**FUNCTIONS**





## Programming LVGAKEYB.COM Functions

The functions can be programmed by (AX=01xxH;INT 18H),  
xx=AL=(key scan codes).

You can program by (MOV AX, 01FFH;INT 18H) to get  
LVGAKEYB HELP message.

The source code of the functions is as follows:

```
C:\>DEBUG
-A
????:0100 MOV AX,01FF
????:0103 INT 18
????:0105 INT 20
????:0107 ^C

-RCX
CX 0000
:7
-N FNHELP.COM
-W
-Q

C:\>FNHELP
```

FUNCTION(FN34H)  
">." = Screen shift right.

```
C:\>DEBUG  
-A  
????:0100 MOV AX,0134  
????:0103 INT 18  
????:0105 INT 20  
????:0107 ^C
```

```
-RCX  
CX 0000  
:7  
-N FN34H.COM  
-W  
-Q
```

```
C:\>FN34H
```

FUNCTION(FN33H)  
"<," = Screen shift left.

```
C:\>DEBUG  
-A  
????:0100 MOV AX,0133  
????:0103 INT 18  
????:0105 INT 20  
????:0107 ^C
```

```
-RCX  
CX 0000  
:7  
-N FN33H.COM  
-W  
-Q
```

C:\>FN33H

FUNCTION(FN32H)

"M" = Screen shift to original display.

C:\>DEBUG

-A

????:0100 MOV AX,0132

????:0103 INT 18

????:0105 INT 20

????:0107 ^C

-RCX

CX 0000

:7

-N FN32H.COM

-W

-Q

C:\>FN32H

FUNCTION(FN17H)

"T" = Toggles LCD Text to inverse/normal

C:\>DEBUG

-A

????:0100 MOV AX,0117

????:0103 INT 18

????:0105 INT 20

????:0107 ^C

-RCX  
CX 0000  
:7  
-N FN17H.COM  
-W  
-Q

C:\>FN17H

FUNCTION(FN18H,FN47H) :  
"L" OR "Fn and Home" = Switch screen to LCD display

C:\>DEBUG  
-A  
????:0100 MOV AX,0118  
????:0103 INT 18  
????:0105 INT 20  
????:0107 ^C

-RCX  
CX 0000  
:7  
-N FN18H.COM  
-W  
-E 101 47  
-N FN47H.COM  
-W  
-Q

C:\>FN18H

FUNCTION(FN26H,FN4FH) :

"O" OR "Fn and End" = Switch screen to external monitor

C:\>DEBUG

-A

????:0100 MOV AX,0126

????:0103 INT 18

????:0105 INT 20

????:0107 ^C

-RCX

CX 0000

:7

-N FN26H.COM

-W

-E 101 4F

-N FN4FH.COM

-W

-Q

C:\>FN26H

FUNCTION(FN49H)

"Fn and PgUp" or "Shift with Alt and +" = Enable Page interleave

C:\>DEBUG

-A

????:0100 MOV AX,0149

????:0103 INT 18

????:0105 INT 20

????:0107 ^C

-RCX  
CX 0000  
:7  
-N FN49H.COM  
-W  
-Q

C:\>FN49H

FUNCTION(FN51H) :  
"Fn and PgDn" or "Shift with Alt and -" = Disable Page interleave  
C:\>DEBUG  
-A  
????:0100 MOV AX,0151  
????:0103 INT 18  
????:0105 INT 20  
????:0107 ^C

-RCX  
CX 0000  
:7  
-N FN51H.COM  
-W  
-Q

C:\>FN51H

FUNCTION(FN0CH,FN4AH) :

"Fn and -" or "Ctrl with Alt and -" = Changes Speed to low

C:\>DEBUG

-A

????:0100 MOV AX,010C

????:0103 INT 18

????:0105 INT 20

????:0107 ^C

-RCX

CX 0000

:7

-N FN0CH.COM

-W

-E 101 4A

-N FN 4AH.COM

-W

-Q

C:\>FN0CH

FUNCTION(FN0DH,FN4EH) :

"Fn and +" or "Ctrl with Alt and +" = Changes Speed to high

C:\>DEBUG

-A

????:0100 MOV AX,010D

????:0103 INT 18

????:0105 INT 20

????:0107 ^C



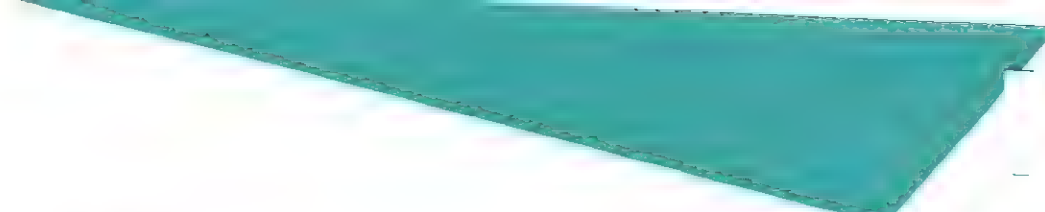

```
-RCX  
CX 0000  
:7  
-N FN0DH.COM  
-W  
-E 101 4E  
-N FN4EH.COM  
-W  
-Q  
  
C:\>FN4EH
```

Appendix D  
ASCII  
CHARACTER  
CODES



DECIMAL VALUE	HEXA DECIMAL VALUE	0	16	32	48	64	80	96	112
0	0	BLANK (NULL)	BLANK (SPACE)						
1	1	␣	!			@	P	␣	p
2	2	␣	"			A	Q	a	q
3	3	␣	!	#		B	R	b	r
4	4	␣	!	\$		C	S	c	s
5	5	♣	!	%		D	T	d	t
6	6	♠	!	&		E	U	e	u
7	7	♣	!	'		F	V	f	v
8	8	♠	!	(		G	W	g	w
9	9	♣	!	)		H	X	h	x
10	A	♠	!	*		I	Y	i	y
11	B	♣	!	+		J	Z	j	z
12	C	♠	!	,		K	[	k	{
13	D	♣	!	-		L	\	l	
14	E	♠	!	.		M	]	m	~
15	F	♣	!	/		N	^	n	~
						O	_	o	Δ





**GLOSSARY**

1  
2  
3  
4  
5  
6  
7  
8  
9  
10  
11  
12  
13  
14  
15  
16  
17  
18  
19  
20  
21  
22  
23  
24  
25  
26  
27  
28  
29  
30  
31  
32  
33  
34  
35  
36  
37  
38  
39  
40  
41  
42  
43  
44  
45  
46  
47  
48  
49  
50  
51  
52  
53  
54  
55  
56  
57  
58  
59  
60  
61  
62  
63  
64  
65  
66  
67  
68  
69  
70  
71  
72  
73  
74  
75  
76  
77  
78  
79  
80  
81  
82  
83  
84  
85  
86  
87  
88  
89  
90  
91  
92  
93  
94  
95  
96  
97  
98  
99  
100

\_\_\_\_\_





dc	Direct current.
DIN	Deutsche Industrie Norm.
DIP	Dual in-line package.
DMA	Direct memory access.
DRAM	Dynamic random access memory.
EGA	Enhanced Graphics Adapter.
F	Fahrenheit.
FCC	Federal Communications Commission.
G	(1) Prefix giga; 1 000 000 000. (2) When referring to computer storage capacity, 1 073 741 824. (1 073 741 824 = 2 to the 30th power.)
Gb	1 073 741 824 bytes.

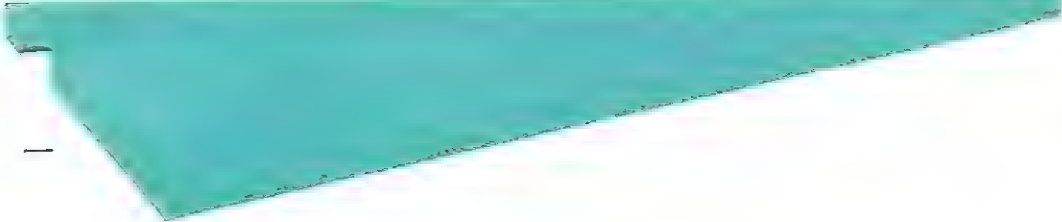

—	GND	Ground.
—	HGC	Hercules monochrome Graphics Card.
—	hex	Common abbreviation for hexadecimal.
—	Hz	Hertz.
—	K	When referring to storage capacity, 1024. (1024 = 2 to the 10th power.)
—	KB	1024 bytes.
—	KHz	Kilohertz; 1000 hertz.
—	LCD	Liquid crystal display.
—	LED	Light-emitting diode.
—	M	(1) Prefix mega; 1 000 000. (2) When referring to computer storage capacity, 1 048 576. (1 048 576 = 2 to the 20th power.)

<b>mA</b>	<b>Milliampere; 0.001 ampere.</b>
<b>Mb</b>	<b>1,048,576 bytes.</b>
<b>MDA</b>	<b>Monochrome Display Adapter.</b>
<b>MFM</b>	<b>Modified frequency modulation.</b>
<b>MHz</b>	<b>Megahertz; 1 000 000 hertz.</b>
<b>ms</b>	<b>Millisecond; 0.001 second.</b>
<b>n</b>	<b>Prefix nano; 0.000 000 001.</b>
<b>ns</b>	<b>Nanosecond; 0.000 000 001 second.</b>
<b>POST</b>	<b>Power-on self-test.</b>
<b>PROM</b>	<b>Programmable read-only memory.</b>
<b>RAM</b>	<b>Random access memory.</b>
<b>ROM</b>	<b>Read-only memory.</b>

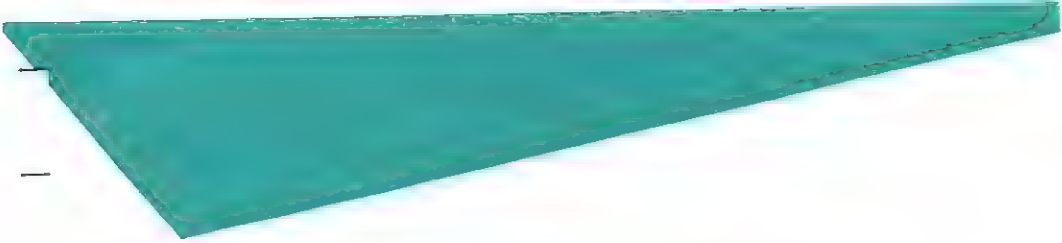

SIMM	Single in-line memory module.
TTL	Transistor-transistor logic.
V	Volt.
Vac	Volts (alternating current).
W	Watt.
access time	The amount of time required for a storage device to begin delivering data after the computer sends a data request.
adapter	An auxiliary device or unit used to extend the operation of another system.
address bus	One or more conductors used to carry the binary-coded address from the processor throughout the rest of the system.
alternating current (AC)	A current that periodically reverses its direction of flow.

active display	In a computer that contains two video subsystems and displays, the display to which a program sends its output.
board	A modular, plug-in circuit that performs a specialized task such as generating vide output.
APA	All points addressable describing video graphics modes.
API	Application program interface used in a application program for basic input and output, file management, and so on.
aspect ratio	The ratio of the video screen's width to its height.
attributes	Color, intensity, blinking, and other displayed characteristics of characters or pixels.
ampere	The basic unit of electric current.

asynchronous  
transmission

A transmission method in which each character is sent one bit at a time. Each character has a start and stop bit to synchronize signals between the sending device and receiving device. This allows a character to be sent at random after the preceding character has been sent.

base I/O address

The beginning address of an I/O port. The base I/O address allows the microprocessor to find the correct port for communicating with a particular device.

base memory address

The beginning address of a block of memory.

base memory

System memory between 0 and 640 KB in which most MS-DOS applications are run.

baud rate

The rate at which data is transferred over a serial interface.

bit

Synonym for binary digit.

BIOS

A set of programs, usually in firmware, that enables each computer's CPU to communicate with printers, disk, keyboards, consoles, and other attached input and output devices.

bps

A unit of measurement representing the number of discrete binary digits transmitted by a device in one second.

board

A rectangular piece of fiberglass that has pins on one side and electronic parts on the other; also called a card, PC board or PCB (printed circuit board). The system is always supplied with a system board. Other boards can include a video adapter board, a disk controller board, a network communication board, memory boards, and multifunction boards.

bootstrap

A technique or device designed to bring itself into a desired state by means of its own action; for example, a machine routine whose first few instructions are sufficient to bring the rest of itself into the computer from an input device.





character set	A set of alphabetic and numeric characters and symbols.
clipping	The process of determining which portions of a graphics image lie within a specified boundary.
code page	A character set designed for use with computers. Each character in a code page is associated with a numeric code (such as ASCII or EBCDIC code).
CRTC	CRT Controller, a chip that controls a video display's timing signals.
capacitor	An electronic circuit component that stores an electric charge.
Celsius ( $^{\circ}\text{C}$ )	A temperature scale. Contrast with Fahrenheit ( $^{\circ}\text{F}$ ).
channel	A path along which signals can be sent; for example, data channel, output channel.

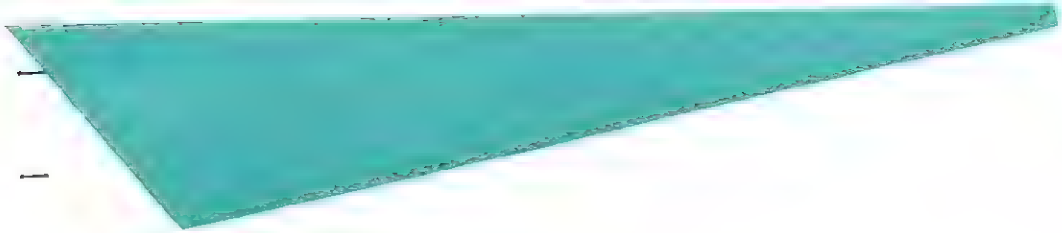

—		
—		
—		
—	CMOS RAM	Random access memory for storing system configuration data (number of bytes, type of drives, amount of memory, etc.). The CMOS RAM is battery maintained and is not available to the computer's operating system.
—		
—	CONFIG.SYS file	A special-purpose file that provides DOS with information about the special kinds of hardware or software used with the computer. Whenever the computer is turned on or rebooted by pressing <Ctrl> <Alt> <Del>, DOS searches the system disk for the CONFIG.SYS file. If DOS finds one, it reads the commands from the file and uses them to prepare the computer for operation.
—		
—	configuration	Hardware: amount and type of hardware installed in a computer system. Memory: amount of memory installed in a computer system and how it is divided among the base, expanded, and extended memory.
—		
—	controller	The circuitry that controls the disk's operations and through which the computer reads from and writes to a fixed disk.
—		
—		

coprocessor	Supplementary microprocessor that processes a specific type of application faster than the system microprocessor. The optional 80287 coprocessor is a numeric coprocessor.
cycle time	Defines the minimum amount of time in which subsequent accesses to a DRAM device can occur.
device driver	A software program that provides an interface between an operating system and a component or subsystem of a computer. For example, the NEATEMM device driver enables the operating system to recognize expanded memory.
diagnostic tests	Test programs designed to detect and identify possible computer malfunctions. The DIAG.EXE program on the User Utility diskette is a collection of diagnostic tests.



**DRAM**

Dynamic RAM. A type of RAM composed of capacitive cells that require periodic refresh to maintain data. All data is lost when the power supply is turned off. The DRAM is slower than the SRAM but the DRAM cell is much smaller than its SRAM counterpart. This enables the DRAM to be a higher density device.

**DTR**

In the IBM Personal Computer, data terminal ready. Associated with modem control.

**DIP**

A widely used container for an integrated circuit. DIPs have pins in two parallel rows. The pins are spaced 1/10-inch apart. See also DIP switch.

**driver**

Software or firmware that directly programs a specific hardware unit such as a video adapter or a printer.

**dynamic memory**

RAM memory using transistors and capacitors as the memory elements. This memory requires a refresh (recharge) cycle every few milliseconds. It requires a continual rewriting of all stored information. Contrast with static memory.

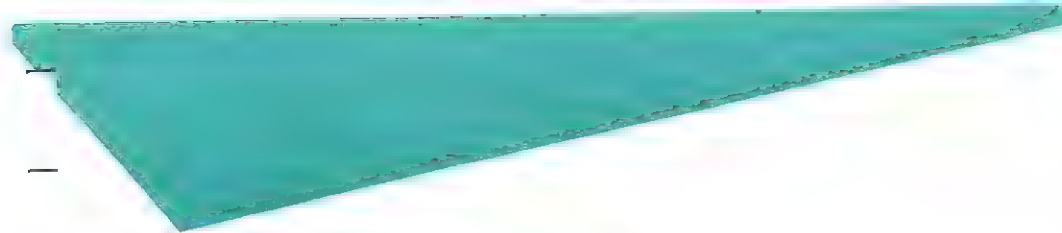

—	edge connector	A terminal block with a number of contacts attached to the edge of a printer-circuit board to facilitate plugging into a foundation circuit.
—	enable	(1) To turn on, especially to restore a feature that has been disabled. (2) To place in a state that will allow certain interrupts to occur in a processing unit. Interrupts are usually enabled by setting a switch or a jumper.
—	EMM	Controls the interface between DOS's application programs and expanded memory.
—	EMS	Expanded memory specification is a page memory handling methodology for application programs and operating systems which require more memory than DOS will provide.
—	Expanded memory	Expanded memory is memory outside DOS's 640K-byte limit (usually in the range of C000h through EFFFFh). Memory addressed between the 640 KB of base memory and one MB of memory; accessed by hardware and software supporting the LIM standard.

Extended memory

Memory addressed above one MB that is accessible through special utilities such as VDISK (found on the User Utility programs diskette) and through certain operating systems. The 15M-byte address range between 100000h thru FFFFFFFh available on an 80286 processor when it is operating in protected virtual address mode.

font

A description of the style and shapes of the characters in a character set.

heads

The parts of a disk drive that pass over the surface of the disk to read or write magnetic information to or from the surface.

interface

(1) A device that alters or converts actual electrical signals between distinct devices, programs, or systems.  
(2) Making two devices capable of communicating.

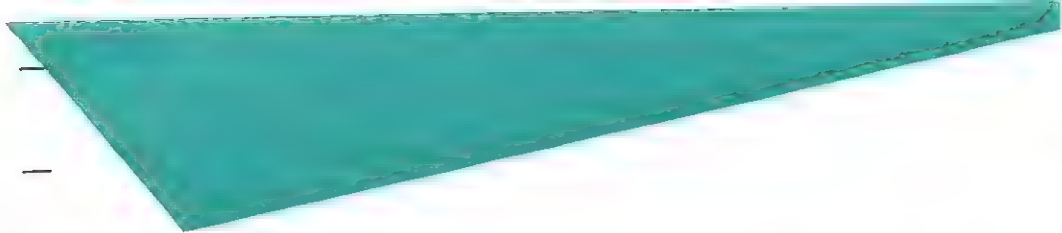

interleave                      The number of fixed disk drive revolutions required to read/write one track of data. Expressed as a ratio; the lower the ratio, the faster the read/write operation. An interleave of four, for example, means that the drive reads every fourth sector as contiguous.

I/O area                         Synonym for buffer.

LED indicator                 Light-emitting diode that lights to indicate a condition; for example, that the power to a component or peripheral is on.

LIM Standard                 Lotus/Intel/Microsoft (LIM) Expanded Memory Specification (EMS). A standard developed to permit access to memory beyond the 640 KB limit imposed by MS-DOS.

logical device                 All or portion of a mass storage device which is perceived and treated as an independent physical drive by the computer's logic. Logical drives are usually designated by letters of the alphabet; for example, as drive A.



megahertz (MHz)	1 000 000 hertz. One million cycles per second.
memory	Term for main storage.
microprocessor	(1) An integrated circuit that accepts coded instructions for execution; the instructions may be entered, integrated, or stored internally. (2) A CPU on a chip; a device that provides the basic arithmetic, logic, and control circuits required for processing.
mode	A method of operation; for example, the binary mode, the interpretive mode, the alphanumeric mode.
modulation	The process by which some characteristic of one wave (usually high frequency) is varied in accordance with another wave or signal (usually low frequency). This technique is used in modems to make business-machine signals compatible with communication facilities.

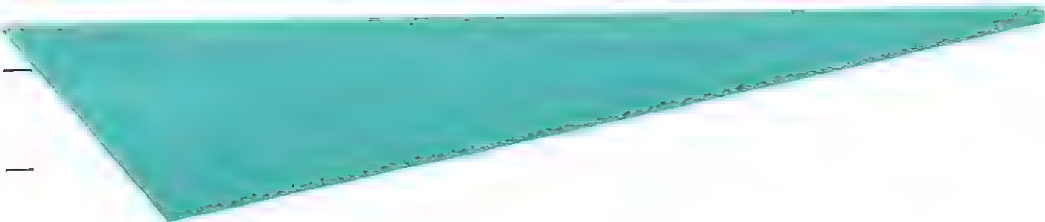

—	monitor	The hardware that displays your computer's video output; comprises a CRT (cathode ray tube) and associated circuitry.
—	operating system	Software that controls the execution of programs and system interaction with peripheral and system devices.
—	paged-mode	The same basic functionality as fast paged-mode, except that the cycle time of the access is the same as a normal RAS/CAS access. This mode is a feature on NMOS-type DRAM parts.
—	park	The action of placing the fixed disk's read/write head in a safe area to prevent damage to the platter. Many drives have a dedicated landing zone for this purpose.
—	parallel port	A printer interface that allows data to be transmitted a byte at a time, all eight bits moving in parallel.
—	parallel printer interface	Standard interface that permits connection of a parallel device, typically a printer, to a system.

parity

A method of checking for errors in transmitted data. The eight bits of each transmitted character are added, and the total must always be an odd number for odd parity or an even number for even parity. If the total is wrong, the communications software detects that an error has occurred during transmission and may request that the data be retransmitted.

parity check

(1) A method of checking the accuracy of binary data after those data have been transferred to or from storage. The number of 1 bits in a binary character is controlled by the addition or deletion of a parity bit. (2) Synonymous with odd-even check.

peripheral

Internal or external device that connects to a computer; examples include a mass storage device, monitor, keyboard, modem, and printer.



power supply

A device that produces the power needed to operate electronic equipment.

RAM

Read/write memory. Random access memory. Data storage device in which all pieces of stored information are directly accessible. Data held in RAM will be lost when the system is turned off, loses power, or is reset.

read

To acquire or interpret data from a storage device, from a data medium, or from another source.

ROM

A storage device whose contents cannot be modified. The memory is retained when power is removed.

ROM/BIOS

The ROM resident basic input/output system, which provides the level control of the major I/O devices in the computer system.

RS-232C

A standard by the EIA for communication between computers and external equipment.



synchronous transmission

Data communications in which characters or bits are sent at a fixed rate, with the transmitting and receiving devices synchronized. This eliminates the need for start and stop bits basic to asynchronous transmission and significantly increases data throughput rates.

system reset

Returning the system to a state that is similar to a power-on state without turning off the power to the computer. The system is reset by pressing and holding the Ctrl and Alt keys, then pressing the Del key. Information not saved before a system reset is lost.

utility

Support program that performs a specific task for the system or the user.

VGA

Video system that allows simultaneous display of up to 256 colors in 640 x 480 graphics resolution and 720 x 400 text resolution.

scan line

One horizontal line traced across the screen by a CRT's electron beam.

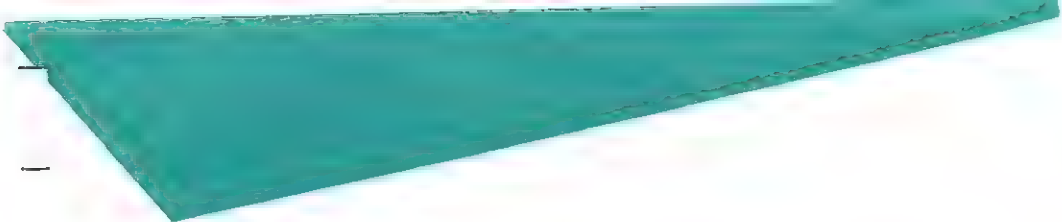

video buffer                      A buffer contains the data that appears on the video display; variously known as a display buffer, frame buffer, refresh buffer, or regenerative buffer.

Video Display Data Area              A global data area maintained by the ROM BIOS for storage of parameters related to its INT 10h video I/O routines.

virtual drive                      A logical drive existing in memory. Because operations occurring in memory are not delayed by having to access physical drives, a virtual drive is much faster than a fixed disk or diskette drive. however, any data in a virtual drive will be lost when the system is turned off or reset. Virtual drives can only be used in extended memory.

wait-state                      An extra or idle 80286 clock state usually associated with memory accesses.

watt                      The practical unit of electric power.



write

To make a permanent or transient recording of data in a storage device or on a data medium.

INDEX

1  
2  
3  
4  
5  
6  
7  
8  
9  
10  
11  
12  
13  
14  
15  
16  
17  
18  
19  
20  
21  
22  
23  
24  
25  
26  
27  
28  
29  
30  
31  
32  
33  
34  
35  
36  
37  
38  
39  
40  
41  
42  
43  
44  
45  
46  
47  
48  
49  
50  
51  
52  
53  
54  
55  
56  
57  
58  
59  
60  
61  
62  
63  
64  
65  
66  
67  
68  
69  
70  
71  
72  
73  
74  
75  
76  
77  
78  
79  
80  
81  
82  
83  
84  
85  
86  
87  
88  
89  
90  
91  
92  
93  
94  
95  
96  
97  
98  
99  
100

1-MB memory board 2-8, 2-11  
25-pin external FDD C-3  
25-pin external printer C-3  
3.5-inch diskette drive 1-1, 2-8  
40 MB embedded fixed-disk  
drive 1-1, 2-1, 2-8  
5-MB DRAM 2-15  
5.25-inch flexible-disk drive 1-  
1, 3-1,  
3-10  
power cord 3-1  
8 MHz 3-15  
80C286 1-1, 2-10, 2-13  
80287 1-4, 2-1, 2-13, 2-16, 3-7

## A

AC adapter 1-1  
auto-repeat 2-9, 5-4

## B

base memory 4-8  
basic system configuration 2-1  
BAD OR MISSING  
COMMAND  
INTERPRETER 6-3  
base Memory 4-10  
battery 4-2  
beep codes B-14  
board layout 2-9

## C

CMOS setup 4-12  
connectors  
socket B-1  
changing CPU speed 3-15  
Cirrus video controller A-3  
COMM2 and COMM1 C-2  
CONFIG.SYS 5-8  
conventional memory 2-13

## D

data storage A-2  
DIAG.EXE 4-13  
DIP switch  
setting 3-11  
diskette drives  
do's and dont's 5-5  
write-protecting flexible  
disks 5-5  
inserting/removing flexible  
disks 5-5  
DISK BOOT FAILURE 6-3  
DISK ERROR 6-2  
display monitor 3-12  
display type 3-15, 4-9

## E

- embedded numeric keypad 1-1, 2-1
- EGA/VGA 4-9
- error messages 6-18
- expanded memory 2-13
- expansion board 3-7
- expansion slot A-1
- extended memory 2-13, 4-8
- external monitor 3-18
  
- external connectors
  - connecting external devices 2-18
  - external keyboard 2-18
  - external monitor 3-18
  - modem 2-19
  - mouse 2-20

## F

- fixed-disk drives 5-6, A-2
- flexible disks and drives 5-5
  - power saver 1-4
- FDD controller C-1
- function Key 2-9, 5-7

## I

**Index-2**

I/O ports A-2

## K

- keyboard 5-2
  - alphanumeric key group 5-3
  - external numeric keypad 5-4
  - edit keypad 5-4
  - cursor keypad 5-4
  - function key group 5-5

## G

- gas plasma display monitor 3-13

## M

- memory
  - boards 2-8
  - base memory 2-10
  - conventional memory 2-10
  - configuration 4-10
  - expanded memory 2-10
  - extended memory 2-10
  - socket 2-11
- microprocessor 2-8, 2-10
- MEM ERROR 6-2
- mouse 3-20

## N

NEATEMM.SYS 5-7, 5-8  
NEATEMM Utility 5-7  
NMI error 6-5  
numeric coprocessor 3-7  
numeric keypad 3-1

## O

onboard memory expansion  
module (RAM) 3-2, A-1  
on-board ROM A-1  
options 3-2  
installing SIMMs 3-1  
expansion boards 3-3  
5.25-inch flexible-disk drive  
3-7  
optional components 1-4  
primary display 4-7  
printer port address 4-8  
scratch RAM option 4-7  
serial ports 4-8  
time 4-5  
optional components  
2-12, 2-13, 3-2  
numeric  
coprocessor 2-10,  
3-2

## P

parallel printer port 3-15  
PARITY CHECK 6-2  
power input A-2  
power source 1-4  
power supply A-2  
power-On self test (POST) 3-20  
printer Port 3-15  
PC-AT chip set 2-7

## R

RAM 2-10  
ROM (read only memory) 2-11, 2-15  
ROM BIOS 2-8  
ROM-based Setup program  
and self-test 5-7

## S

serial COM1 port 3-12  
serial COM2 port 3-12  
serial ports 3-15

Setup program 4-2  
  COM option 4-10  
  date and time 4-7  
  diskette drive types 4-8  
  fixed disk drive types and  
    format 4-9  
  HDD OFF timer value 4-  
    11  
  keyboard 4-9  
  LCD OFF timer value 4-10  
  memory type and size 4-31  
  primary display 4-8  
  PRN option 4-9  
  scratch RAM option 4-10  
  shadow RAM/interleave 4-  
    13, 14  
  shadow memory 4-10  
  SIMMs 2-15  
  Soft Switches 3-16  
  SETUP program 4-1  
    CPU operating speed  
      4-8  
    date 4-5  
    diskette drive types 4-6  
    fixed disk drive types 4-6  
    keyboard 4-7  
    onboard COM2 port  
      4-8  
    shadow RAM/interleave 4-10  
  shadowing the system BIOS  
    2-11  
  system unit controls and  
    indicators 5-1, 2-2  
  configuration 2-1

features 2-2  
standard components  
  2-8  
system software utilities 5-6

**U**  
utilities  
  CONFIG.SYS 5-2  
  NEATEMM.SYS 5-1, 5-2  
  SRAY.EXE 5-1, 5-4

**V**  
video ROM A-1  
video port C-2

Archived by:  
[www.  
retrospace.  
net](http://www.retrospace.net)